

- **280 W AC-DC / 3" X 5.3" FOOTPRINT**
- **AVAILABLE MODELS: 12V – 56V**
- **UP TO 90% EFFICIENCY**
- **HIGH POWER DENSITY: OVER 13 W / in³**
- **ALL OUTPUTS MAY BE PARALLELED**
- **REMOTE ON / OFF**
- **5V STANDBY OUTPUT (1A)**
- **12V AUX OUTPUT (1A)**
- **UNIVERSAL AC INPUT**
- **ACTIVE PFC (90 – 264 VAC)**
- **ACTIVE CURRENT SHARING FOR N, N+1**
- **ACTIVE INRUSH CURRENT PROTECTION**
- **RoHS COMPLIANT**



POWER SUPPLY DESIGN LEADER

N2Power™ leads the power density race with its high efficiency XL280 Series AC-DC power supplies. Our advanced technology yields a very small footprint, reduces wasted power, and

TWICE THE POWER IN HALF THE SPACE

offers the highest power density in its class. This efficient design means reduced energy costs, a greater return on your investment, greater reliability and longer product life.

UNMATCHED POWER DENSITY

With an overall height of 1.35" and a 3" x 5.3" footprint, the XL280 Series boasts a power density over 13 watts per cubic inch. It is ideally suited for OEMs using the industry standard 1U chassis.

HIGH EFFICIENCY IN A SMALL PACKAGE

The XL280 Series provides up to 90% efficiency. Our unique design reduces energy consumption and generates less wasted heat. It requires little forced air cooling, decreases AC power consumption, increases reliability and economy of operation. Comparisons of efficiencies show that our supplies can reduce losses up to 50%.

COMPLETE PROTECTION

The main output is enabled whenever all of the required startup conditions are met, and is shut down upon command, loss of input power or whenever excessive loads or temperatures are sensed. When AC input power is lost it provides the host system with advanced warning of an impending shutdown.

Typical Mechanical Drawing:

Inches (millimeters), refer to XL280 Product Specification for complete information.

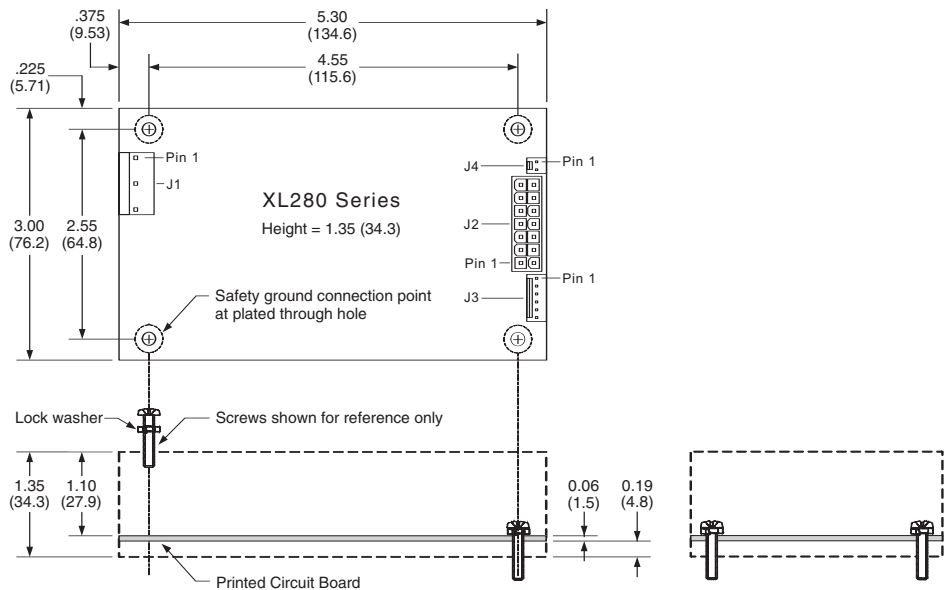

MODEL	PART NUMBER	OUTPUT	VOLTAGE	REGULATION (%)	MAXIMUM CURRENT (A)	RIPPLE & NOISE (P-P)
XL280-12 XL280-12 CS	400082-01-2	V1	12	±3	23.3	120 mV
		V2	12	±5	5.0	120 mV
	400081-01-4	V3	12	±5	1.0	120 mV
		V4	5sb	±5	1.0	50 mV
XL280-24 XL280-24 CS	400082-02-0	V1	24	±3	11.7	240 mV
		V2	12	±5	5.0	120 mV
	400081-02-2	V3	12	±5	1.0	120 mV
		V4	5sb	±5	1.0	50 mV
XL280-48 XL280-48 CS	400082-03-4	V1	48	±3	5.8	480 mV
		V2	12	±5	5.0	120 mV
	400081-03-0	V3	12	±5	1.0	120 mV
		V4	5sb	±5	1.0	50 mV
XL280-54 XL280-54 CS	400082-04-6	V1	54	±3	5.2	540 mV
		V2	12	±5	5.0	120 mV
	400081-04-8	V3	12	±5	1.0	120 mV
		V4	5sb	±5	1.0	50 mV
XL280-56 XL280-56 CS	400082-05-3	V1	56	±3	5.0	560 mV
		V2	12	±5	5.0	120 mV
	400081-05-5	V3	12	±5	1.0	120 mV
		V4	5sb	±5	1.0	50 mV

CS = Current Sharing

INPUT SPECIFICATIONS	
Nominal Input Voltage:	100 – 240 VAC
Tested Input Limits:	90 – 264 VAC
Input Frequency Range:	47 – 63 Hz
Input Current:	3.5 A @ 100 VAC
Input Protection:	5 A fuse
Safety Isolation:	3000 VAC input to output 1500 VAC input to ground
Inrush Current:	14 A @ 240 VAC†
Power Factor Correction:	Active PFC circuitry, meets or exceeds EN61000-3-2
Leakage Current:	0.75mA @ 240 VAC / 60 Hz†

OUTPUT SPECIFICATIONS	
Total Output:	280 W
Hold-up Time:	Minimum 22 mS
Efficiency:	Up to 90%†
Minimum Load:	No load†
Over / Under Shoot:	Maximum 10% at turn-on
Output Isolation:	For POE†
PROTECTION	
Overvoltage Protection:	V1 (latches off)
Overpower Protection:	Protected / Auto Recovery
Short Circuit Protection:	Auto recovery of all outputs
Thermal Shutdown:	Auto recovery protection against over temperature conditions

† See Product Specification Δ Some Models

OPERATING SPECIFICATIONS	
Operating Temperature:	-25°C to +50°C
Temperature Derating:	2.5% / degree 50°C to 70°C
Storage Temperature:	-40°C to +85°C
Forced Air Cooling:	10 CFM minimum†
Convection Cooling:	See Specification ^Δ
MTBF:	546,464 hours @ 25°C*
SIGNALS	
Remote Sense:	V1 and Return
Current Sharing:	V1 using active circuitry
Passive Redundancy:	V2 and V3 outputs may be wire OR-ed
Power Good (PG) Output:	High - true CMOS logic
Remote Enable Input:	Low-true input enables V1, V2, V3 output

* See MTBF Report for additional temperature values

Compliance:†

USA / Canada:

Safety: Underwriters Laboratories: UL 60950-1:2007 (2nd Edition) / C22.2 No. 60950-1-07 Safety of Information Technology Equipment (ITE)

EMC: FCC part 15, subpart B

† See Product Specification for additional information

Europe:

2006/95/EC - "Low Voltage (Safety) Directive"
Demko: EN 60950-1:2006+A11:2009 (2nd Edition)

2004/108/EC "Electromagnetic Compatibility (EMC) Directive"
EN 61204-3 Class B

International:

IEC 60950-1:2005 (2nd Edition) Safety of Information Technology Equipment

IEC 61204-3 Class B

