

X5000A3

Three-Phase Rectifier Module



Overview:

The Eltek Valere three-phase X rectifier is designed for applications requiring high capacity, high-power density, and scalable growth. Utilizing a robust platform, this rectifier features industry-leading power density, flexibility, and ease of use. With a wide input voltage range and high efficiency, they provide an ideal solution in for large power needs.

Applications

Scalable Power System

Three-phase X-series rectifiers, in conjunction with the Eltek Valere Scalable Power System, provide the ideal solution for such applications as central offices, mobile telephone switching offices (MTSO), and other switching centers that require large-scale power rectification - typically in the range of 1000 to 10,000 amps.

Flexibility and Reliability

X-series rectifiers have a wide input AC voltage range, simplifying inventory and installation. Whether the AC supply is 380VAC or 480VAC, the X-series rectifiers accommodate, eliminating the need to stock spare rectifiers for different voltages.

Plug and Play

Eltek Valere rectifiers are hot-swap units. Scalable DC Power Systems, which use the X-series rectifier, can grow from 1000 amps to 10,000 amps simply by inserting additional rectifiers to the existing system without interrupting system performance.

Global Compliance

Eltek Valere is committed to meeting customer requirements worldwide. The X-series rectifier meets such global compliance standards such as CSA, VDE, and NEBS.

Features

- Wide input voltage operating range
- Three-phase input (delta)
- Up to 5800 watts of output power
- 2RU in height
- Operates in temperatures up to 65°C
- Power factor correction
- Hot-pluggable/hot-swappable
- AC OK, DC OK, and ALM (alarm) LED indicators
- Internal over-temperature protection
- Internal OR-ing protection
- Internal surge protection to 6000V
- Up to 15 modules can populate a Scalable rectifier bay, providing up to 1500 amps per bay
- Up to 92.5% efficiency
- CSA Certified
- VDE Certified
- NEBS Level 3

Three-Phase X-series Rectifier

Technical Specifications

Document
2042765 R1

AC INPUT

X SERIES	X5000A3	NOTES
Input Voltage (nominal)	320 - 530Vac	
Input Frequency (min)	47 Hz	
Input Frequency (max)	63 Hz	
Input Current (max)		4-wire delta only (Phases A, B, and C; and Ground)
@ 320 Vac (amps)	13	
@ 380 Vac (amps)	12	
@ 400 Vac (amps)	10	
@ 480 Vac (amps)	9	
Inrush Current (max)	30 amps peak	Excludes X caps in the EMC input filter.
Power Factor (480Vac)	.98	Typical at Full Load

DC OUTPUT

MAIN OUTPUT	X5000A3	NOTES
Vo Set Point (min/typ/max)	42/48/58V	
Regulation (min/max)	±1%	Total regulation line, load, aging & temperature)
Output Current (min/max amps)	0/100	
Current Limit Setpoint (max amps)	110	Current limit set point is adjustable via I ² C or through Network Interface Card.
Short Circuit Current (RMS amps)	35	
Output Noise*	<ul style="list-style-type: none"> o 40 mV rms typical (10kHz to 20MHz) o 45 dBnC (measured w/o external battery) o 250mV P-P (10 KHz to 20 Mhz) 	
Output Rise Time*	100/500 (msec)	Measured at 10 – 90% of final output level
Dynamic Response* (maximum)	3%	Change in output voltage within 10 msecs after a 25% load step change
Turn On Delay* (maximum)	3.5 sec	Measured from application of valid ac voltage to regulation set-point.
Adjustable Over-voltage Protection (min/max)	54/60 (Vdc) remotely config.	
Backup Over-voltage Protection	60 Vdc	
Load Sharing (min/max)	±5 (%) of full load	
Total Harmonic Distortion (THD)	<3% typical	At full rated current
Efficiency	92% typical	At 480Vac, 25-100% of rated current

AUXILIARY OUTPUT

AUXILIARY OUTPUT	X5000A3	NOTES
Output 1		
Nominal Voltage	12V	
Vmin/max	10.5 / 14	
Source Current Rating (min/max)	0 / 500mA	
Sink Current (max)	100mA	Current required for internal controls when AC is not present

NOTE: Output 1 operates independent of main DC output and is referenced to Vout-

Three-Phase X-series Rectifier

Technical Specifications

Document
2042765 R1

PHYSICAL DIMENSIONS

PARAMETER	X5000A3	NOTES
Depth	323.85mm (12.75")	
Height	86.36mm (3.40")	
Width	263.90mm (10.39")	
Weight	8.18 kg (18 lbs)	

ENVIRONMENTAL SPECIFICATIONS

PARAMETER	Minimum	Maximum	UNIT	NOTES
Storage Temperature	-40	85	°C	
Operating Temperature	-40	65	°C	Power Derating: 2% / °C above 50°C
Humidity	5	95	%	Relative Humidity Non Condensing
Altitude	-200	8000	Ft	For operation above 8000' , maximum temperature is derated 2°C per 1000' for temps above 65

GENERAL REQUIREMENTS

APPLICABLE STANDARDS			
Seismic Rating	Zone 4, per GR-63-CORE	EN61000-4-2	Electrostatic discharge immunity test, 15kV air, 8kV contact
Radiated EMI	Conforms to EN55022, Level A	EN61000-4-3	Radiated radio-frequency, electromagnetic field immunity test. 10 V/m
Conductive Emissions	EN55022, Level A	EN61000-4-4	Electrical fast transient/burst immunity test. 1kV
NEBS	EMC surge standards and electrical safety per GR-1089-CORE	EN61000-4-5	Surge immunity test. 6kV: Line to line 6kV: Line to ground
		EN61000-4-6	RF common mode. 3Vrms

Specifications are subject to change without notice

Efficiency at 480VAC

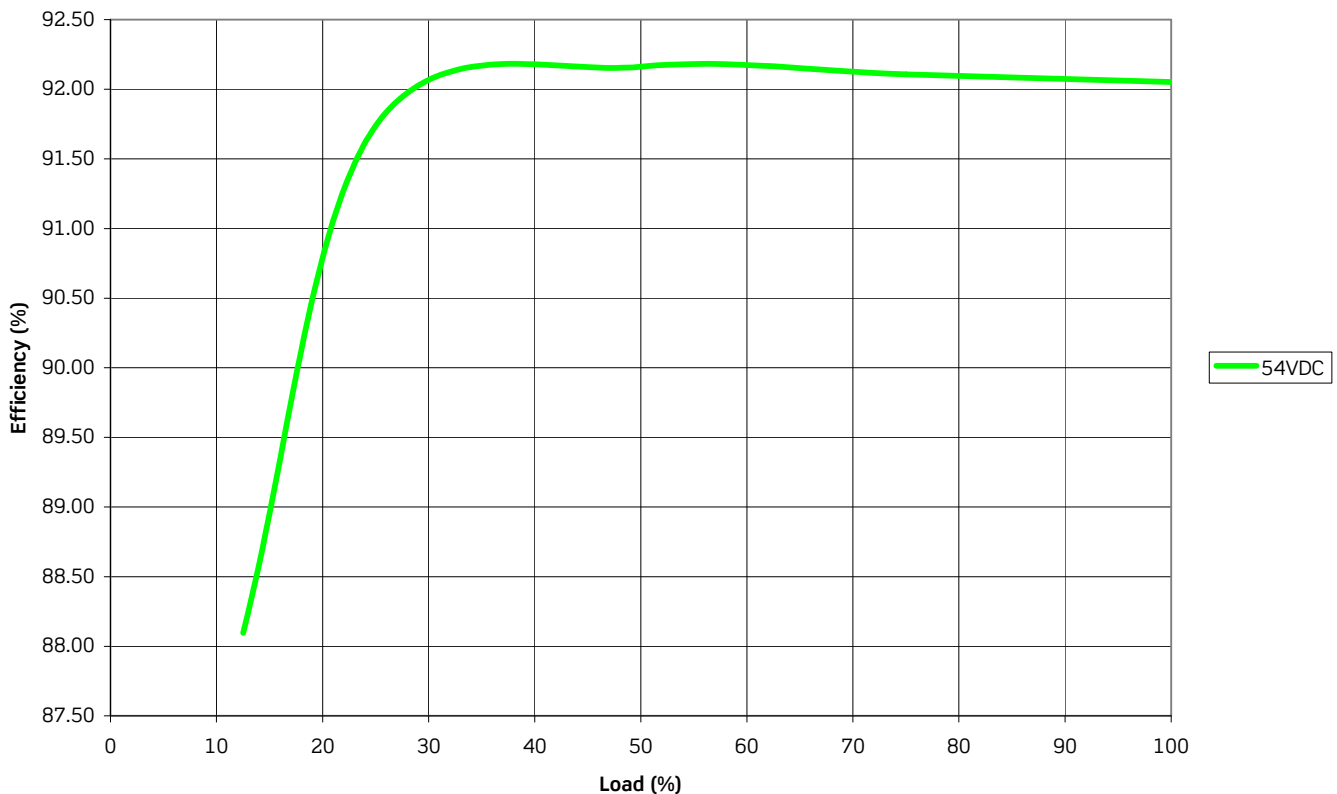

Three-Phase X-series Rectifier

Dimensional Drawings

Document
2042765 R1

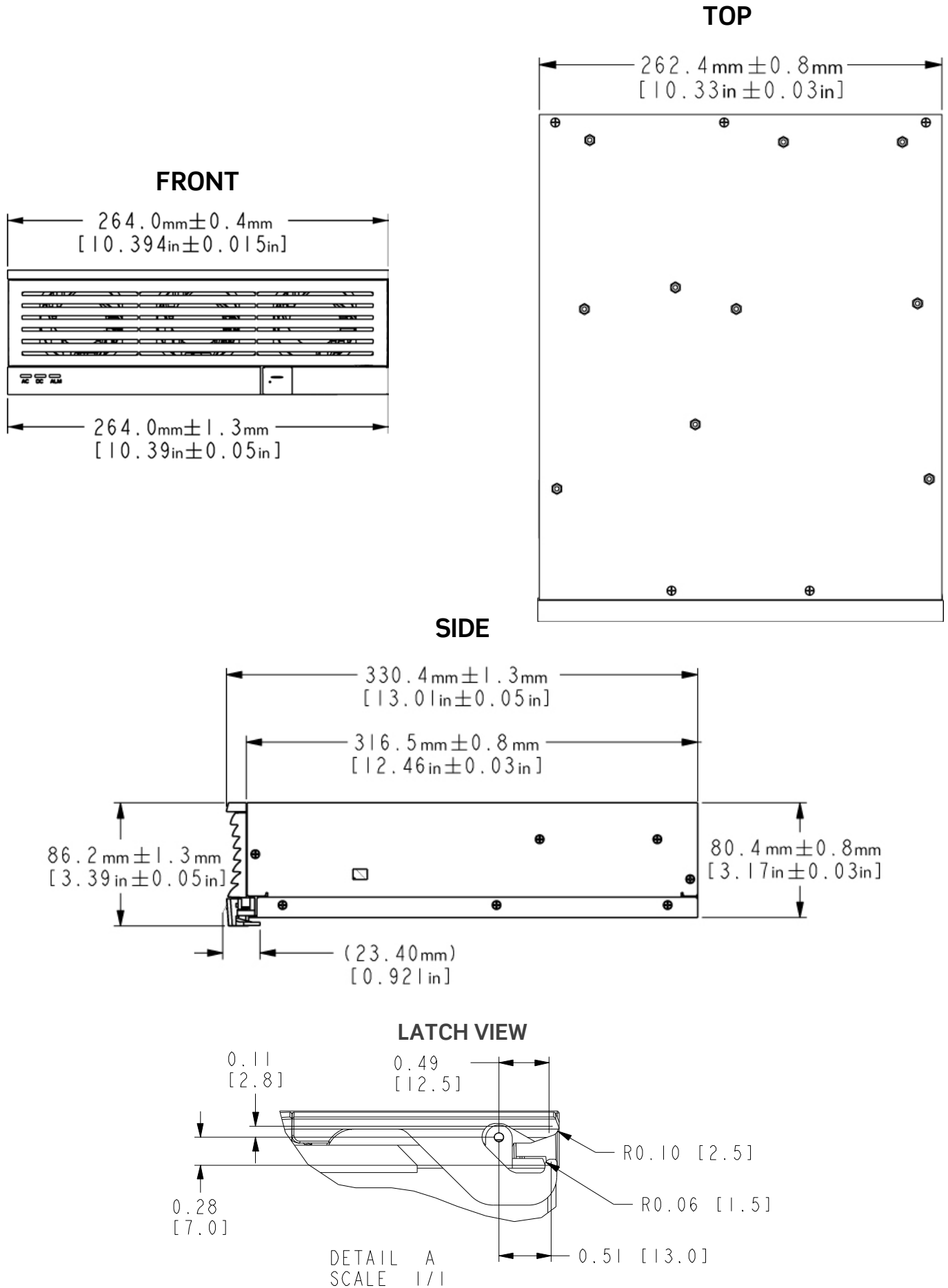

Three-Phase X-series Rectifier

Document
2042765 R1

Rear View (AC and DC connectors)

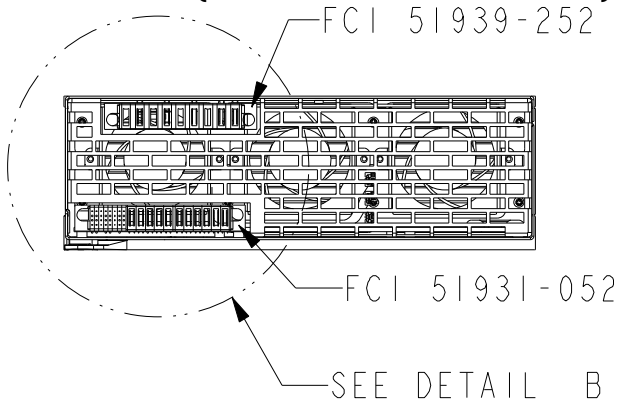

Rear View (Close up)

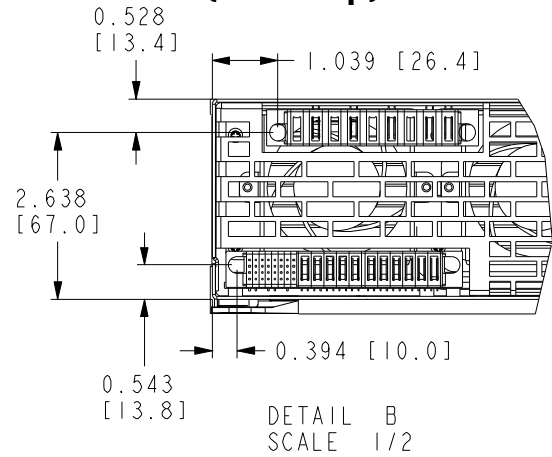

DC Output Connector

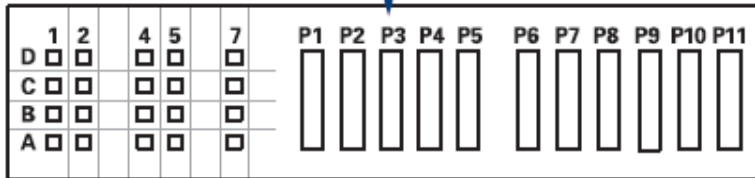

Unit DC output
Connector p/n: 51939-259LF
Mating Connector p/n: 51940-027LF (Straight) or 51915-122LF (Right Angle)
Supplier: FCI/Berg

FCI NUMBERING	1	2	4	5	7
D	TEMP_FAIL	SDA	LOC3	Shelf-Bias	SHORT_PIN
C	REMOTE_OFF	SCL	RESERVED	LOC2	REMOTE_SENSE-
B	AC_FAIL	MODULE_ALARM	ISHARE	LOC1	RESERVED
A	MODULE_PRST	LOGIC_GROUND	V_MARGIN	LOC0	REMOTE_SENSE+
P1	OUTPUT NEGATIVE				
P2					
P3					
P4					
P5					
P6	OUTPUT POSITIVE				
P7					
P8					
P9					
P10					
P11	RESERVED				

AC Input Connector

Connector p/n: 51939-252LF
Mating Connector p/n: 10066439-011
Supplier: FCI/Berg

FCI NUMBERING	PIN ASSIGNMENT
P1	CHASSIS GROUND
P2	CHASSIS GROUND
P3	NOT POPULATED
P4	PHASE 3
P5	NOT POPULATED
P6	PHASE 2
P7	NOT POPULATED
P8	PHASE 1
P9	NOT POPULATED

Non Isolated Signals

OUTPUT+ and OUTPUT-

Power blades used for connecting positive and negative power connections.

REMOTE_SENSE+ and REMOTE_SENSE-

These signals are used to compensate for distribution drop across the output distribution. The maximum voltage drop from the rectifier module to the remote sense connection (the complete round trip) must be maintained to less than 1V. The remote sense leads may be left un-terminated in applications where remote voltage regulation is not required.

ISHARE

All rectifiers ISHARE pins are tied together on the system backplane to support load sharing. This connection may be terminated between rectifiers or left un-terminated in systems where load share is not required.

SHORT_PIN

The short pin is used to disable the rectifier if not fully seated in a system. It is required to be tied to OUTPUT- in the system backplane in order for the rectifier to provide proper output voltage. It may not be left un-terminated.

Isolated Signals

Address Pins (LOC0, LOC1, LOC2, LOC3)

LOC0, LOC1, LOC2 and LOC3 are location pins used to set rectifier address in a system where the I²C bus is shared between rectifiers. They may be left un-terminated to generate logic 1 or connected to OUTPUT- to generate logic 0.

I²C Communications Bus (SCL, SDA)

The I²C Communications Bus provides information about internal rectifier conditions as well as full control of output voltage and alarming set points. SCL and SDA are common data signals and can be wired directly to a system controller or on a common shared bus between the rectifiers in a system and the main system controller. The rectifiers communicate via a proprietary communication protocol. Contact your *Eltek Valere* representative for technical assistance in interfacing to the rectifiers using this protocol. The I²C Bus signals are logic referenced to LOGIC_GROUND. The internal bias for the I²C isolation circuit will support a 10V common mode voltage differential to OUTPUT-.

Isolated Signals (cont.)

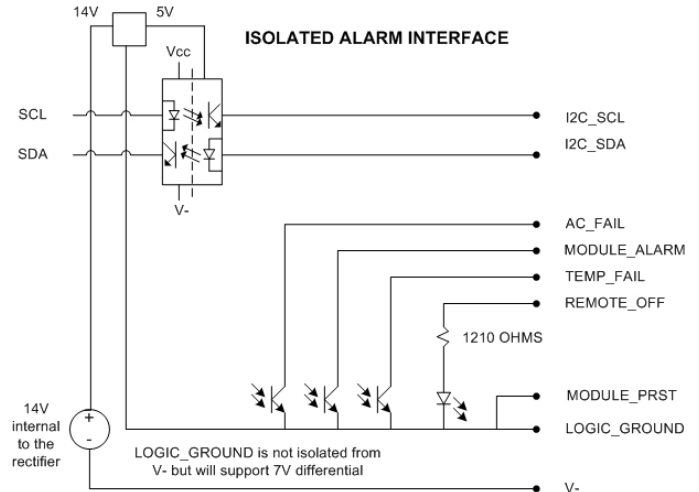

AC_FAIL

This signal is an opto-isolated open collector signal referenced to LOGIC_GND within each rectifier. AC_FAIL is a normally closed signal which signifies the presence of an alarm with a high impedance. AC_FAIL indicates the presence of valid AC input voltage to the rectifier.

MODULE_ALARM

This signal is an opto-isolated open collector signal referenced to LOGIC_GND within each rectifier. MODULE_ALARM is a normally closed signal which signifies the presence of an alarm with a high impedance. MODULE_ALARM is designed to provide an power fail warning to indicate the pending loss of DC voltage during line drop conditions. MODULE_ALARM is asserted at least 5mSec prior to loss of DC output voltage during these conditions.

TEMP_FAIL

This signal is an opto-isolated open collector signal referenced to LOGIC_GND within each rectifier. TEMP_FAIL is a normally closed signal which signifies the presence of an alarm with high impedance. TEMP_FAIL indicates that the rectifier module has shut down due to an over-temperature condition.

REMOTE_OFF

This signal is a current limited input designed to accept a 3.3V to 5V input voltage. Applying a voltage between these pins will result in disabling the DC output voltage from the rectifier. This signal may be left un-terminated in systems where REMOTE_OFF is not required or is implemented via the I²C Interface.

MODULE_PRST ("Present")

This signal is a connection to logic ground. It may be used to determine the presence of a rectifier module in a system location.