



Features

- ◆ Switch mode power supplies for DIN-rail mount
- ◆ 6 power ranges with 2, 3, 6, 12, 20 and 24 A output current (24 VDC models)
- ◆ Selectable 115/230 VAC input
- ◆ Very low ripple and noise
- ◆ EMI complies with EN 61000-6-3 and EN 61000-6-4
- ◆ Operating temp. range -25°C to $+70^{\circ}\text{C}$
- ◆ For system operation available with built-in functions:
 - RED:** Redundancy module for N+1 Systems with true current sharing
 - SIG:** Signal module with AC-power-fail, power good signal and external On/Off control
 - UDS:** DC-UPS module for uninterruptible battery backed-up power systems
- ◆ Worldwide safety approvals incl. class I, div. 2 location
- ◆ Easy snap-on mount on DIN-rails or chassis mount
- ◆ 3-year product warranty



The switching power supplies of the TIS series have been particularly designed for applications in industrial process control systems and with machine tools. Excellent specifications and high immunity against electrical disturbances guarantee reliable power for sensitive loads in rugged industrial environments. With the help of optional function modules specific requirements for system applications can be easily realized with a standard model. With the UDS module the power supplies can be extended to a perfect DC-UPS with automatic battery- backup. This function is very often required in applications where a time delayed shutdown of a system is necessary. To monitor and control the power supply a signal module can be installed. For parallel operation with active power sharing a redundancy option is available. This flexibility makes the TIS series power supplies a cost effective solution for many industrial applications.

Models

Order Code (includes terminal plugs)	Input Voltage nom.	Output Power max.	Output Voltage nom.	Output Current max.
TIS 50-112 TIS 50-124	115–240 VAC universal input	50 W	12 VDC 24 VDC	3.5 A 2.0 A
TIS 75-112 TIS 75-124 TIS 75-148	115/230 VAC selectable	75 W	12 VDC 24 VDC 48 VDC	6.0 A 3.0 A 1.5 A
TIS 150-124 TIS 150-148	115/230 VAC selectable	150 W	24 VDC 48 VDC	6.0 A 3.0 A
TIS 300-124 TIS 300-148 TIS 300-172	115/230 VAC selectable	300 W	24 VDC 48 VDC 72 VDC	12.0 A 6.0 A 4.2 A
TIS 500-124-115 TIS 500-124-230	115 VAC 230 VAC	500 W 500 W	24 VDC 24 VDC	20.0 A 20.0 A
TIS 600-124 TIS 600-148 TIS 600-172	115/230 VAC selectable	600 W	24 VDC 48 VDC 72 VDC	24.0 A 12.0 A 8.5 A

Input Specifications

Input voltage range	TIS 50: 93 – 264 VAC TIS 75, 150, 300, 600: 93 – 132 VAC / 187 – 264 VAC TIS 500-124-230: 187 – 264 VAC TIS 500-124-115: 93 – 132 VAC																					
Input frequency	47 – 63 Hz																					
Input current at full load (typ.)	<table border="1"> <thead> <tr> <th></th> <th>at 115 VAC</th> <th>at 230 VAC</th> </tr> </thead> <tbody> <tr> <td>TIS 50:</td> <td>0.85 A</td> <td>0.50 A</td> </tr> <tr> <td>TIS 75:</td> <td>1.3 A</td> <td>0.75 A</td> </tr> <tr> <td>TIS 150:</td> <td>2.7 A</td> <td>1.6 A</td> </tr> <tr> <td>TIS 300:</td> <td>4.9 A</td> <td>2.9 A</td> </tr> <tr> <td>TIS 500:</td> <td>6.0 A</td> <td>4.3 A</td> </tr> <tr> <td>TIS 600:</td> <td>7.0 A</td> <td>5.0 A</td> </tr> </tbody> </table>		at 115 VAC	at 230 VAC	TIS 50:	0.85 A	0.50 A	TIS 75:	1.3 A	0.75 A	TIS 150:	2.7 A	1.6 A	TIS 300:	4.9 A	2.9 A	TIS 500:	6.0 A	4.3 A	TIS 600:	7.0 A	5.0 A
	at 115 VAC	at 230 VAC																				
TIS 50:	0.85 A	0.50 A																				
TIS 75:	1.3 A	0.75 A																				
TIS 150:	2.7 A	1.6 A																				
TIS 300:	4.9 A	2.9 A																				
TIS 500:	6.0 A	4.3 A																				
TIS 600:	7.0 A	5.0 A																				
Recommended circuit breaker, characteristic C or fuse, slow blow typ	<table border="1"> <tbody> <tr> <td>TIS 50:</td> <td>5.0 A</td> </tr> <tr> <td>TIS 75:</td> <td>5.0 A</td> </tr> <tr> <td>TIS 150:</td> <td>10.0 A</td> </tr> <tr> <td>TIS 300:</td> <td>15.0 A</td> </tr> <tr> <td>TIS 500:</td> <td>15.0 A</td> </tr> <tr> <td>TIS 600:</td> <td>20.0 A</td> </tr> </tbody> </table>	TIS 50:	5.0 A	TIS 75:	5.0 A	TIS 150:	10.0 A	TIS 300:	15.0 A	TIS 500:	15.0 A	TIS 600:	20.0 A									
TIS 50:	5.0 A																					
TIS 75:	5.0 A																					
TIS 150:	10.0 A																					
TIS 300:	15.0 A																					
TIS 500:	15.0 A																					
TIS 600:	20.0 A																					

Output Specifications

Output voltage adj. range	<table border="1"> <tbody> <tr> <td>12 VDC models:</td> <td>12 – 14 VDC</td> </tr> <tr> <td>24 VDC models:</td> <td>24 – 28 VDC</td> </tr> <tr> <td>48 VDC models:</td> <td>48 – 52 VDC</td> </tr> <tr> <td>72 VDC models:</td> <td>60 – 76 VDC</td> </tr> </tbody> </table>	12 VDC models:	12 – 14 VDC	24 VDC models:	24 – 28 VDC	48 VDC models:	48 – 52 VDC	72 VDC models:	60 – 76 VDC				
12 VDC models:	12 – 14 VDC												
24 VDC models:	24 – 28 VDC												
48 VDC models:	48 – 52 VDC												
72 VDC models:	60 – 76 VDC												
Regulation	<table border="1"> <tbody> <tr> <td>– Input variation</td> <td>0.2 %</td> </tr> <tr> <td>– Load variation (10–90%)</td> <td>TIS 50, TIS 75, TIS 150: 1.0 % TIS 300, TIS 500, TIS 600: 0.3 % (2.0 % in parallel operation)</td> </tr> </tbody> </table>	– Input variation	0.2 %	– Load variation (10–90%)	TIS 50, TIS 75, TIS 150: 1.0 % TIS 300, TIS 500, TIS 600: 0.3 % (2.0 % in parallel operation)								
– Input variation	0.2 %												
– Load variation (10–90%)	TIS 50, TIS 75, TIS 150: 1.0 % TIS 300, TIS 500, TIS 600: 0.3 % (2.0 % in parallel operation)												
Ripple and noise (20MHz bandwidth)	<50 mV pk-pk												
Electronic short circuit protection	current limitation at 110 % typ. (constant current, automatic restart)												
Over voltage protection, trigger point at	140 % typ. Vout nom.												
Hold-up time	<table border="1"> <thead> <tr> <th></th> <th>115 VAC</th> <th>230 VAC</th> </tr> </thead> <tbody> <tr> <td>TIS 50 ... TIS 300:</td> <td>min. 25 ms</td> <td>min. 30 ms</td> </tr> <tr> <td>TIS 500:</td> <td>min. 20 ms</td> <td>min. 40 ms</td> </tr> <tr> <td>TIS 600:</td> <td>min. 15 ms</td> <td>min. 25 ms</td> </tr> </tbody> </table>		115 VAC	230 VAC	TIS 50 ... TIS 300:	min. 25 ms	min. 30 ms	TIS 500:	min. 20 ms	min. 40 ms	TIS 600:	min. 15 ms	min. 25 ms
	115 VAC	230 VAC											
TIS 50 ... TIS 300:	min. 25 ms	min. 30 ms											
TIS 500:	min. 20 ms	min. 40 ms											
TIS 600:	min. 15 ms	min. 25 ms											

General Specifications

Temperature ranges	<ul style="list-style-type: none"> – Operating (ambient temp.) – Derating above 50 °C (122 °F) – Storage (non operating) 	–25°C to +70°C (–13°F to +158°F) 2%/K –25°C to +85°C (–13°F to +185°F)
Humidity (non condensing)		95 % rel. H max.
Pollution degree		2
Temperature coefficient		0.02 %/K
Switching frequency		80 kHz typ. (pulse width modulation)
Efficiency	TIS 50 ... TIS 300: TIS 500: TIS 600:	85 % typ. 90 % typ. 90 % typ.
Isolation		according to IEC/ EN 60950, UL 60950, UL 508
Reliability, calculated MTTF (MIL-HDBK-217F, @+25°C, ground benign)	TIS 50/75: TIS 150/300: TIS 500/600:	450'000 h / 420'000 h 420'000 h / 360'000 h 340'000 h / 300'000 h
Safety standards		IEC/ EN 60950-1 (SELV, except 72 VDC models) UL/cUL 60950-1, UL 508, UL/cUL 1604
Safety approvals	<ul style="list-style-type: none"> – CB report – UL approvals 	for IEC 60950 www.tracopower.com/products/tis_cb.pdf UL/cUL 60950, File E181381 UL/cUL 508, File E210002 UL/cUL 1604, File E213613 not for TIS 50 & 500 (Class I, Div. 2, Groups A, B, C and D hazardous locations) www.ul.com -> certifications
Electromagnetic compatibility (EMC), Emissions	<ul style="list-style-type: none"> – Conducted RI suppression on input – Radiated RI suppression – Harmonic current emissions 	EN 61000-6-3 / EN 61000-6-4 EN 55011 class B, EN 55022 class B, FCC part 15, level B EN 55011 class A, EN 55022 class A, FCC part 15, level A EN 61000-3-2, class A
Electromagnetic compatibility (EMC), Immunity	<ul style="list-style-type: none"> – Electrostatic discharge (ESD) – Radiated RF field immunity – Electrical fast transient / burst immunity – Surge immunity – Immunity to conducted RF disturbances – Power frequency field immunity 	EN 61000-6-2 IEC/EN 61000-4-2 4 kV/8 kV IEC/EN 61000-4-3 10 V/m IEC/EN 61000-4-4 2 kV IEC/EN 61000-4-5 2 kV/4 kV IEC/EN 61000-4-6 10 V IEC/EN 61000-4-8 30 A/m
Safety class		degree of electrical protection 1 (IEC 536)
Case protection		IP 20 (IEC 529)
Environment	<ul style="list-style-type: none"> – Vibration – Shock 	IEC 60068-2-6; 1 gn, 200 sweeps, each axis IEC 60068-2-27; 15 gn, 11 ms, each axis
Enclosure material		aluminium (chassis) / zinc plated steel (cover)
Mounting (snap-on with self locking spring)		for 35 mm DIN-rails as per EN 50022
Connection		detachable screw terminal block (plugs included) (TIS 600: fixed screw terminal block)

Instruction manual can be downloaded under:
www.tracopower.com/productsts/tis_manual.pdf

All specifications valid at nominal input voltage, full load and +25 °C after warm-up time unless otherwise stated.

Power Supplies with Redundancy Function

With this option a parallel operation of up to 5 units is possible. Decoupling diodes and current share lines allow to build true N +1 redundant systems with active current sharing for all units. This function also includes an alarm relay to signal a single unit failure.

This option is available for TIS 150 W, TIS 300 W and TIS 600 W models.

Please note: This option cannot be combined with other options.

Models

Order Code (includes terminal plugs)	Input Voltage	Output Power max.	Output Voltage nom.	Output Current max.
TIS 150-124 RED	115/230 VAC	150 W	24 VDC	6.0 A
TIS 150-148 RED	selectable		48 VDC	3.0 A
TIS 300-124 RED	115/230 VAC	300 W	24 VDC	12 A
TIS 300-148 RED	selectable		48 VDC	6.0 A
TIS 600-124 RED	115/230 VAC	600 W	24 VDC	24 A
TIS 600-148 RED	selectable		48 VDC	12 A

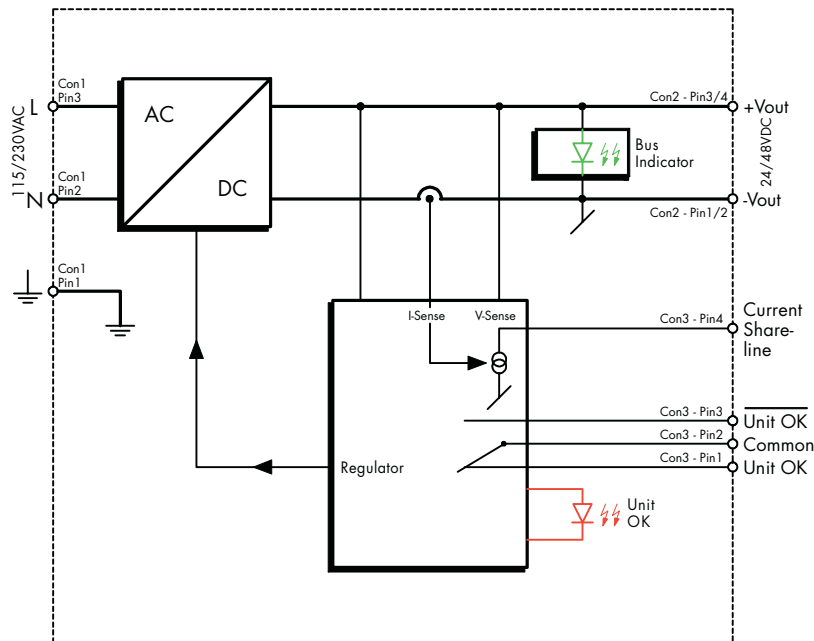

Specifications

Rating per relay contact 60 VDC /0.36 A max.

Instruction manual for RED option can be downloaded under:
http://www.tracopower.com/products/tis_red_manual.pdf

Power Supplies with Powerfail Functions

These models provide 3 functions required in many process control system applications:

- ◆ AC-Powerfail signal (relay contact)
- ◆ Power Good signal (relay contact)
- ◆ Remote On/Off

Models

Order Code (includes terminal plugs)	Input Voltage	Output Power max.	Output Voltage nom.	Output Current max.
TIS 150-124 SIG	115/230 VAC	150 W	24 VDC	6.0 A
TIS 150-148 SIG	selectable		48 VDC	3.0 A
TIS 300-124 SIG	115/230 VAC	300 W	24 VDC	12 A
TIS 300-148 SIG	selectable		48 VDC	6.0 A
TIS 600-124 SIG	115/230 VAC	600 W	24 VDC	24 A
TIS 600-148 SIG	selectable		48 VDC	12 A

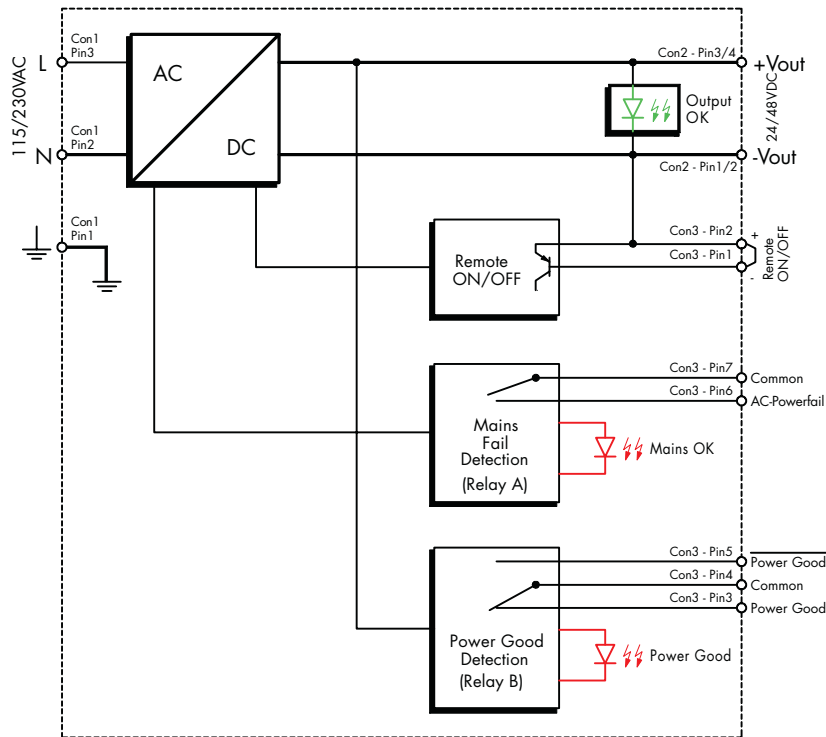

Specifications

Power Good signal trigger point	models with 24 Vout: >22.8 VDC ±0.5 V relay B closed (pin 4 – pin 3) models with 48 Vout: >45.6 VDC ±1.0 V relay B closed (pin 4 – pin 3)
AC-Powerfail signal	Vin <93 resp. <187 VAC relay A closed (pin 7 – pin 6)
Rating per relay contact	60 VDC /0.36 A max.
Remote On/Off	– On – Off short circuit con 3 pin 1 and pin 2 open circuit con 3 pin 1 and pin 2

Instruction manual for SIG option can be downloaded under:
http://www.tracopower.com/products/tis_sig_manual.pdf

DC-UPS-System



In addition to the standard power supply function, these models include a professional battery management system to charge and monitor an external battery. In the event of a power failure the battery is switched automatically and without any interruption to the DC output. Once mains power is available again, the battery is switched off. The backup time is limited only by battery capacity and load. Charge current and voltage can be adjusted to values as required by battery type. Power fail and low battery alarm signals

are available via two independent relay contacts. During normal operation the battery status is monitored by periodically loading the battery for a short time. If a cell resistance is high, there is a relay alarm is available. The battery is fully protected under any operational conditions. The power supply is short circuit protected even in battery backup operation but, for safety reasons, the battery should be fitted with a fast blow fuse. Battery mode can be activated by interconnecting pin 7 and 8.

Complete external battery packs (3.2 Ah or 7 Ah standard) with lead batteries and circuit breaker are available (see page 8).

Models				
Order Code ¹⁾	Input Voltage	Output Power max.	Output Voltage nom.	Output Current ²⁾ max.
TIS 300-124 UDS	115/230 VAC selectable	300 W	24 VDC	12 A
TIS 600-124 UDS	115/230 VAC selectable	600 W	24 VDC	24 A

1) Includes terminal plugs, does not include batteries

2) reduce max. output current by battery charging current

DC-UPS-System

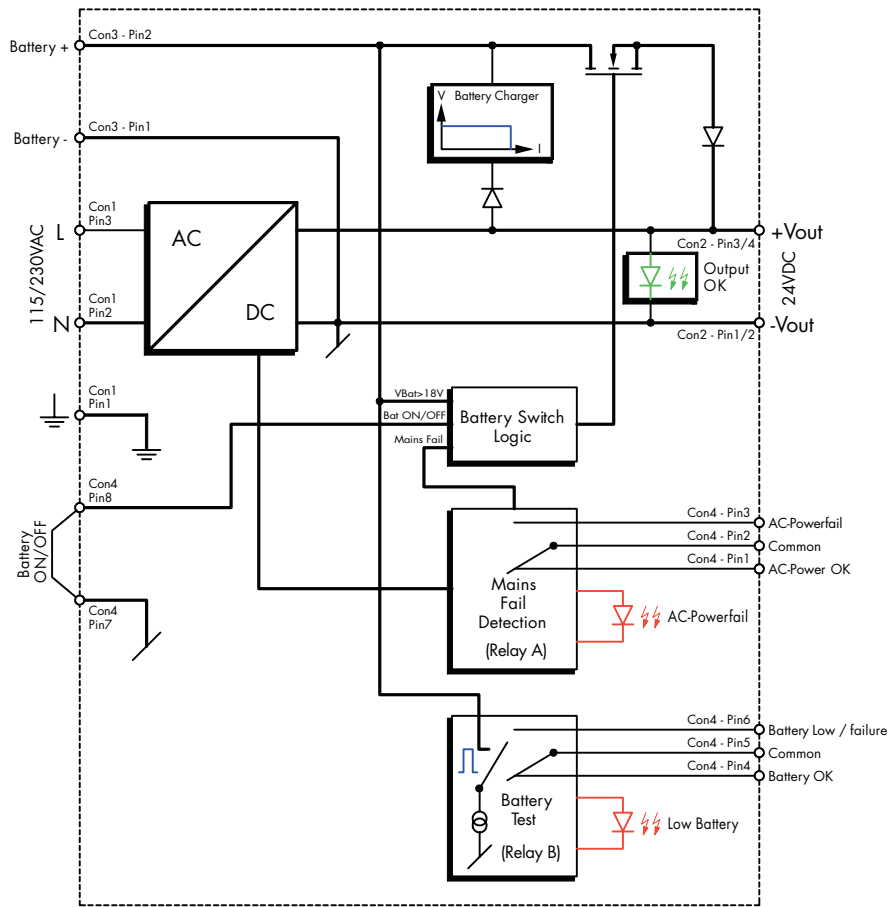

Specifications

Charging current (factory set)	TIS 300-124 UDS: 1.2 A TIS 600-124 UDS: 2.4 A
Adjustment range of charging current	TIS 300-124 UDS: 0.15 – 1.5 A TIS 600-124 UDS: 0.25 – 2.5 A
Holding current for charged battery at voltage 27.3 VDC	<50 mA
Overload or short circuit during battery operation	system switches off
AC-Powerfail signal	Vin <93 or <187 VAC relay A closed (pin 2 – pin 3)
Low battery signal	– Battery voltage below 22 V – Raiting per relay contact relay B closed (pin 5 – pin 6) 60 VDC /0.36 A max.
During battery charge operation output current reduction by 1.4 x battery charge current	

Instruction manual for UDS option can be downloaded under:
http://www.tracopower.com/products/tis_uds_manual.pdf

Battery-Pack for DC-UPS Systems

The battery pack contains high quality, maintenance free lead-acid batteries with 3.2 Ah or 7.0 Ah capacity. The batteries are fixed together with a re-settable electronic fuse on a solid mounting frame. Together with power supply models TIS 300-124 UDS or TIS 600-124 UDS the battery pack provides a complete and reliable DC-UPS system.

Backup time depends on load current and battery capacity.

Models

Order Code	Battery Voltage	Battery Capacity (25 °C, 20 h-rate)	Permissible Charge Current max.
TIS 24-32 AP	24 VDC	3.2 Ah	1.2 A
TIS 24-70 AP	24 VDC	7.0 Ah	2.4 A

Specifications

Max. charge voltage	27 – 27.6 VDC	
Temperature coefficient	–36 mV/°C	
Temperature range	– at charge operation	–15°C to +50°C
	– at load operation	–20°C to +60°C
	– Storage	–20°C to +60°C
Average lifetime on standby operation at tA =20°C	4 – 5 years	
Cable length	1.0 m	
Cable diameter	TIS 24-32 AP:	2.5 mm ² (AWG 12)
	TIS 24-70 AP:	4.0 mm ² (AWG 11)
Weight	TIS 24-32 AP:	2.9 kg (6.4 lb)
	TIS 24-70 AP:	4.1 kg (9.1 lb)
Recommended combinations (power supplies)	TIS 24-32 AP:	TIS 300-124 UDS
	TIS 24-70 AP:	TIS 600-124 UDS

Case Dimensions

TIS 50 models

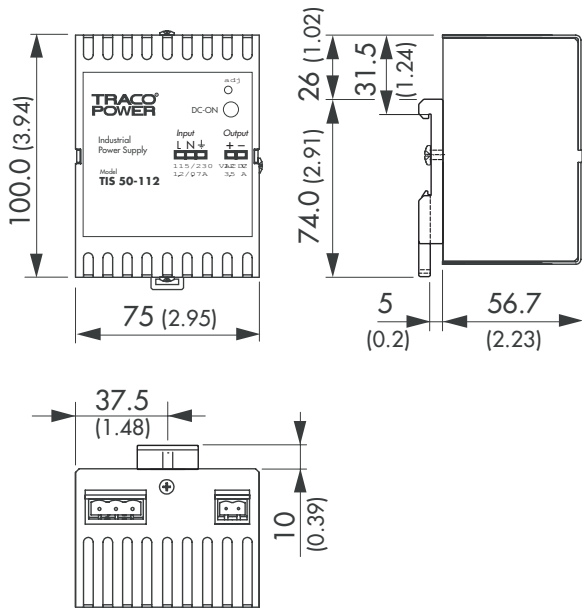

Weight: 0.41 kg (0.9 lb)

TIS 75 models

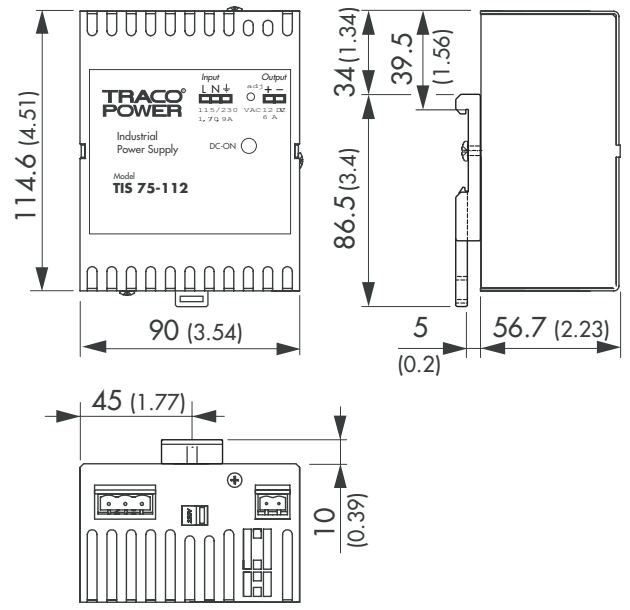

Weight: 0.48 kg (1.06 lb)

TIS 150 models

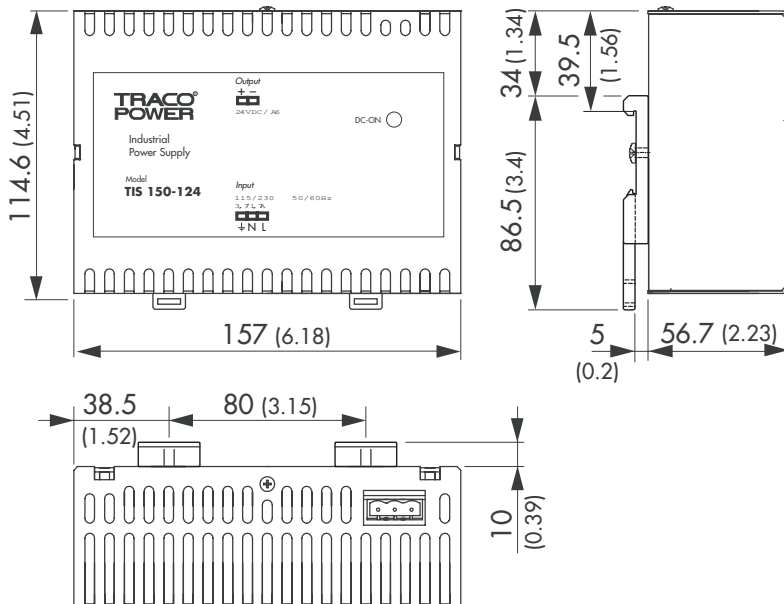

Weight: 0.80 kg (1.76 lb)

Dimensions in [mm], () = Inch
Tolerances: ± 0.5 (± 0.02)

Case Dimensions

TIS 300 models

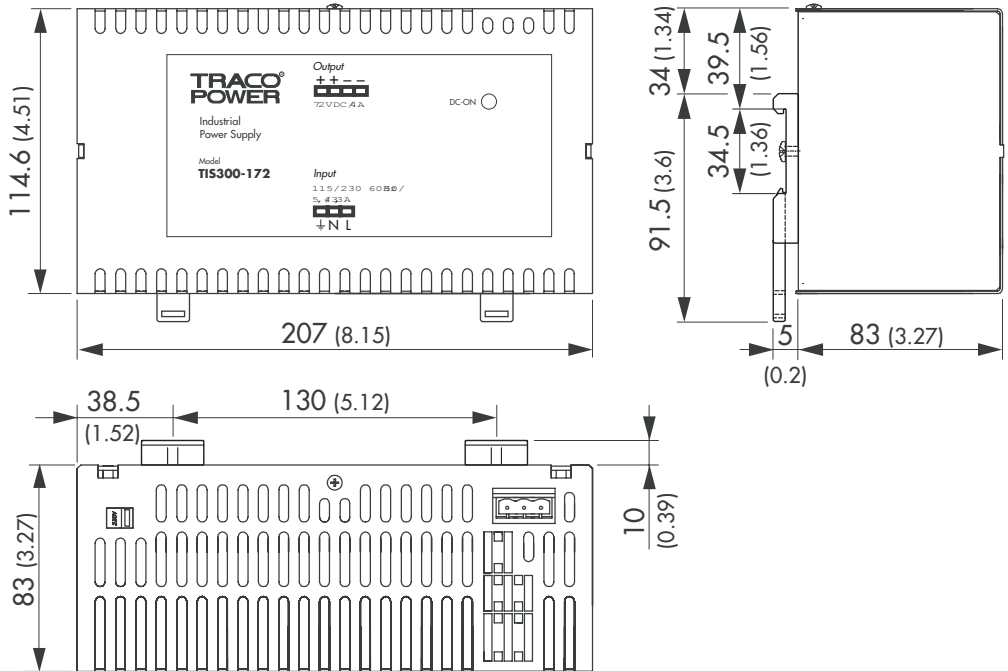

Weight: 1.4 kg (3.09 lb)

TIS 500 models

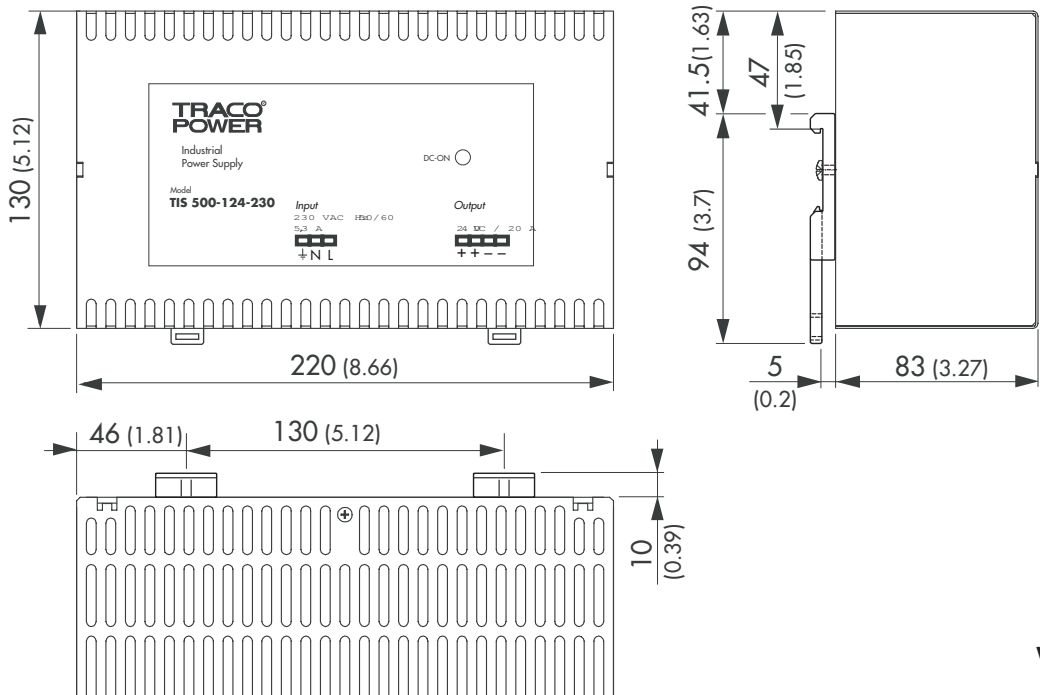

Weight: 1.9 kg (4.19 lb)

Dimensions in [mm], () = Inch
Tolerances: ± 0.5 (± 0.02)

Outline Dimensions mm (inches)

TIS 600 models

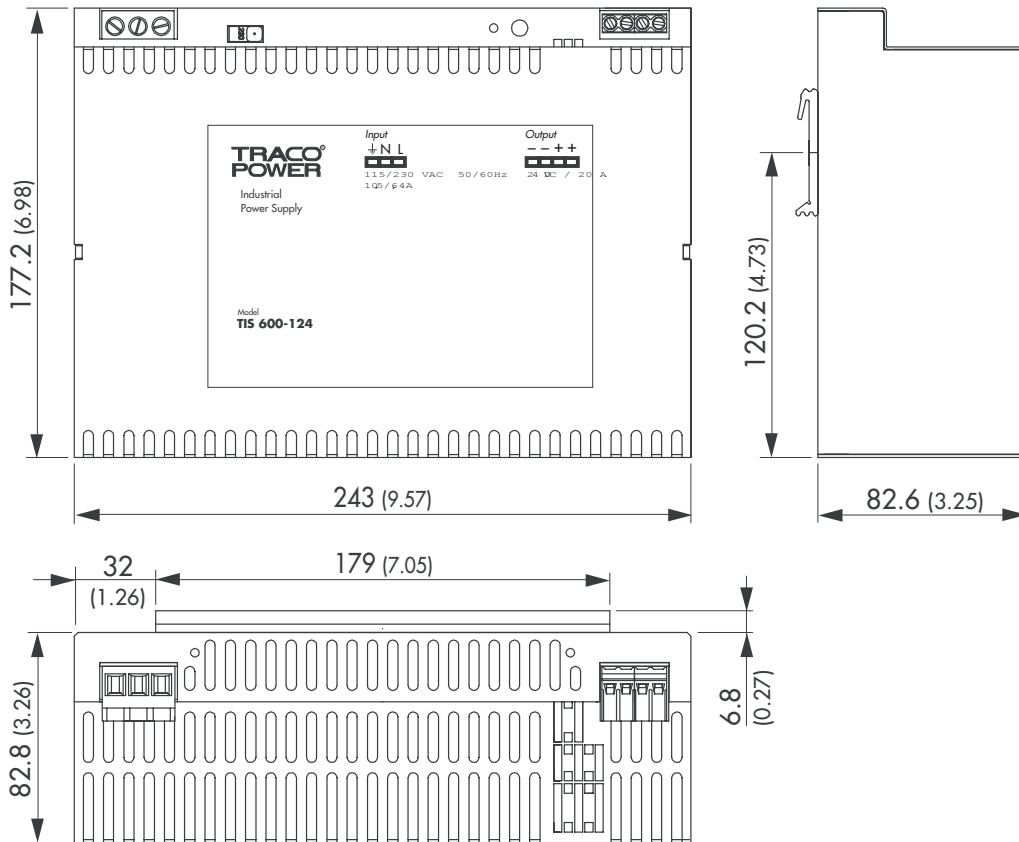

Weight: 2.0 kg (4.41 lb)

Dimensions in [mm], () = Inch
Tolerances: ± 0.5 (± 0.02)

Optional Mounting Systems

Wall mounting kit

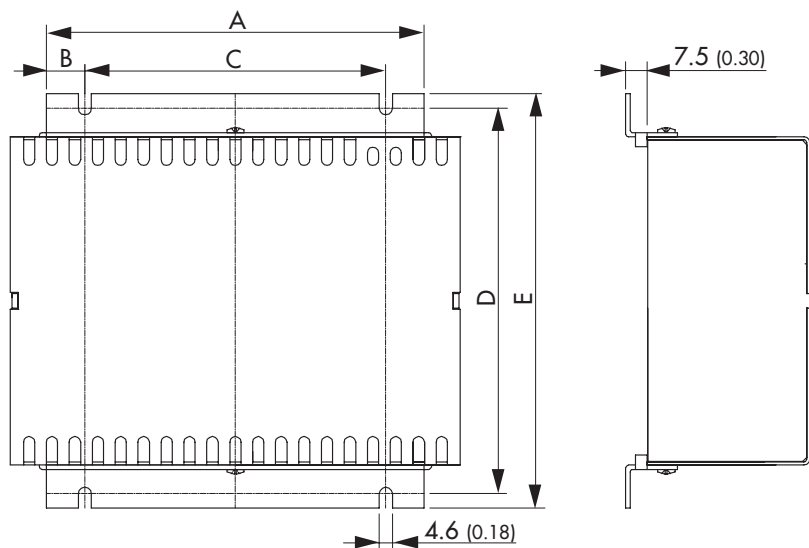

Models	Order code	A	B	C	D	E
TIS 75	MK-75	37 (1.46)	14.5 (0.57)	–	134.5 (5.30)	150.5 (5.93)
TIS 150	MK-150	132 (5.20)	13.5 (0.53)	105 (4.13)	134.5 (5.30)	150.5 (5.93)
TIS 300	MK-300	132 (5.20)	13.5 (0.53)	105 (4.13)	134.5 (5.30)	150.5 (5.93)
TIS 500	MK-500	132 (5.20)	13.5 (0.53)	105 (4.13)	134.5 (5.30)	150.5 (5.93)
TIS 600	MK-600	190 (7.48)	37.5 (1.48)	115 (4.53)	197.0 (7.76)	207.0 (8.15)

Rugged DIN-Rail mounting kit

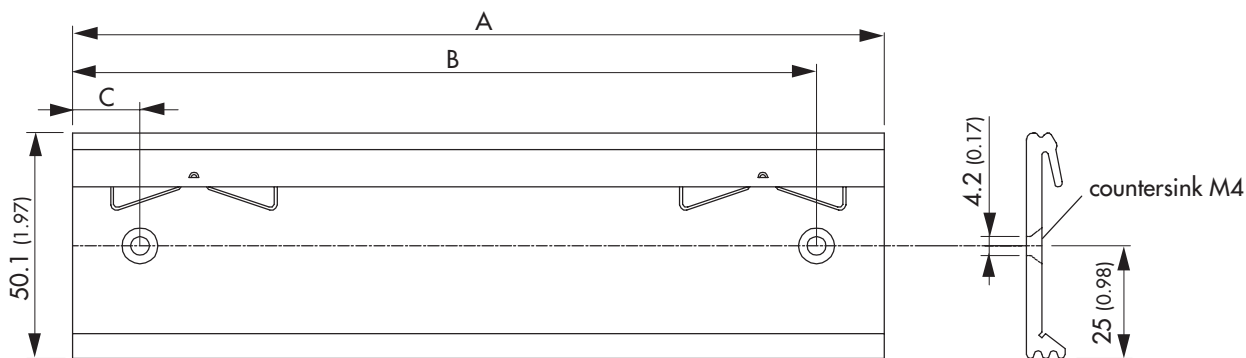

Models	Order code	A	B	C
TIS 150	RMK-150	150 (5.91)	115 (4.53)	35 (1.38)
TIS 300	RMK-300	200 (7.87)	165 (6.50)	35 (1.38)
TIS 500	RMK-300	200 (7.87)	165 (6.50)	35 (1.38)
TIS 600	standard	180 (7.09)	165 (6.50)	15.0 (0.59)

Dimensions in [mm], () = Inch
Tolerances: ±0.5 (±0.02)

Outline Dimensions mm (inches)

TIS-24-32 AP

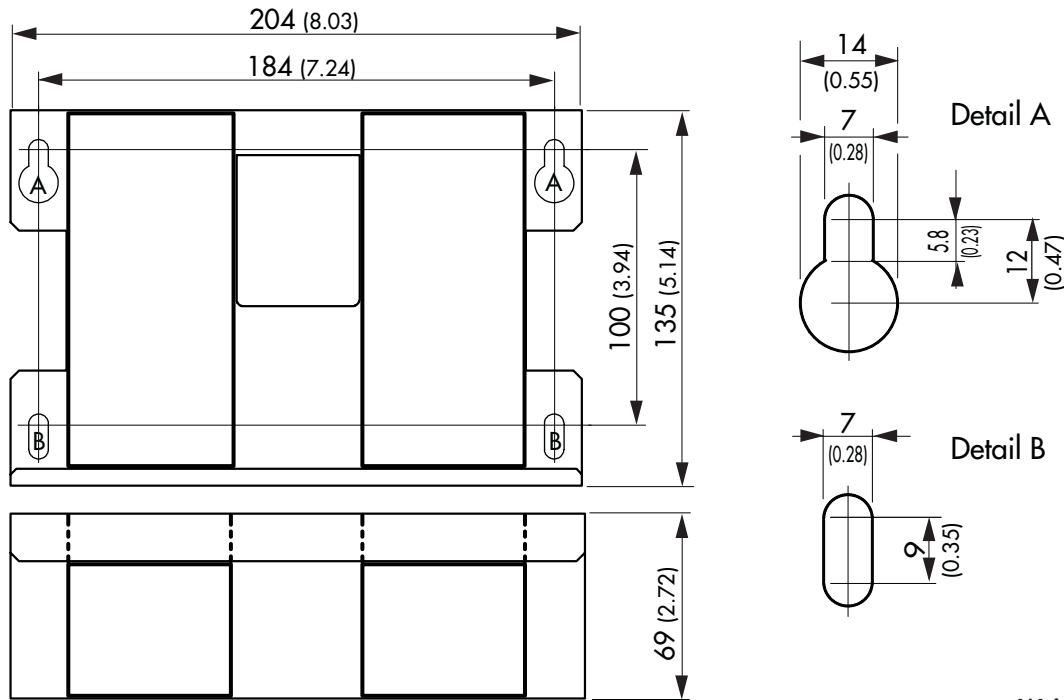

TIS-24-70 AP

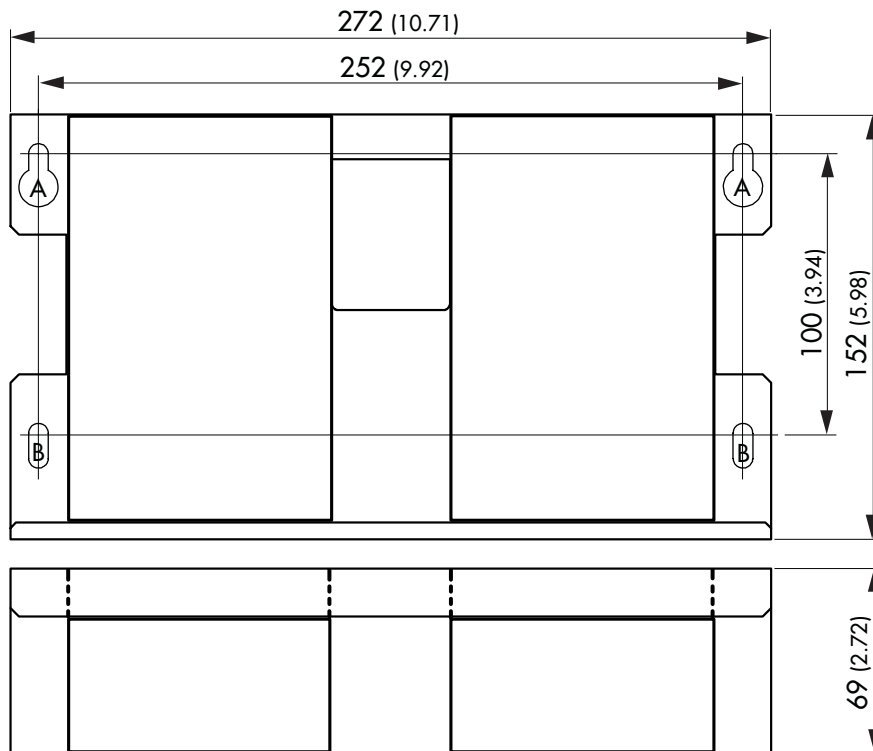

Weight (incl. batteries):

TIS-24-32 AP	2.9 kg (6.4 lb)
TIS-24-70 AP	4.1 kg (9.1 lb)

Dimensions in [mm], () = Inch
Tolerances: ±0.5 (±0.02)

Specifications can be changed any time without notice.