

Features

- ◆ Smallest encapsulated 15 W converter
Ultra compact size: 25.4x25.4x10.2mm
- ◆ Single- and dual output models
- ◆ I/O isolation voltage 1500 VDC
- ◆ High efficiency up to 87 %
- ◆ Operating temp. range: -25°C to +71°C
- ◆ Remote On/Off
- ◆ Industry standard pinout
- ◆ Lead free design, RoHS compliant
- ◆ 3-year product warranty

not recommended for new design in



The THD-15 series is the latest generation of high performance 15W dc-dc converter modules setting new standards concerning power density. This product comes in a encapsulated package with dimensions of only 25.4 x 25.4 x 10mm and therefore occupies 50 %(!) less board space than existing 15W converters.

All models have wide 2:1 input voltage range and precisely regulated, isolated output voltages. Built-in filters for both input and output minimizes the need for external filtering. Further features include remote On/Off and short circuit protection. Typical applications for these converters are battery operated equipment, instrumentation, distributed power architectures in communication and industrial electronics and everywhere where space is limited on the PCB.

Models

Order code	Input voltage range	Output voltage	Output current max.	Efficiency typ.
THD 15-2410	18 – 36 VDC (nominal 24 VDC)	3.3 VDC	3'500 mA	84 %
THD 15-2411		5.1 VDC	3'000 mA	85 %
THD 15-2412		12 VDC	1'250 mA	86 %
THD 15-2413		15 VDC	1'000 mA	86 %
THD 15-2422		±12 VDC	±600 mA	85 %
THD 15-2423		±15 VDC	±500 mA	85 %
THD 15-4810	36 – 75 VDC (nominal 48 VDC)	3.3 VDC	3'500 mA	84 %
THD 15-4811		5.1 VDC	3'000 mA	86 %
THD 15-4812		12 VDC	1'250 mA	87 %
THD 15-4813		15 VDC	1'000 mA	87 %
THD 15-4822		±12 VDC	±600 mA	85 %
THD 15-4823		±15 VDC	±500 mA	85 %

Input Specifications

Input current (no load)	24 Vin models: 50 mA typ. 48 Vin models: 30 mA typ.
Input current (full load)	24 Vin; 3.3 Vout models: 570 mA typ. 24 Vin; other output models: 730 mA typ. 48 Vin; 3.3 Vout models: 280 mA typ. 48 Vin; other output models: 360 mA typ.
Start-up voltage / under voltage shut down	24 Vin models: 17 VDC /16.5 VDC 48 Vin models: 34.0 VDC /32.5 VDC
Surge voltage (100 msec. max.)	24 Vin models: 50 V max. 48 Vin models: 100 V max.
Conducted noise (input)	EN 55022 level A, FCC part 15, level A (with external input capacitor, see Note 1)

Output Specifications

Voltage set accuracy	±1 %
Regulation	– Input variation Vin min. to Vin max: 0.5 % max. – Load variation 10–100% single output models: 0.5 % max. dual output models balanced: 2.0 % max. dual output models unbalanced: 5.0 % max.
Ripple and noise (20 MHz Bandwidth)	100 mVpk-pk max. (with external output capacitor, see Note 1)
Temperature coefficient	±0.02 %/K
Output current limitation	>105 % of Iout max., foldback
Short circuit protection	indefinite (automatic recovery)
Start-up time	30 ms max.
Max. capacitive load	1200 µF

General Specifications

Temperature ranges	– Operating: –25°C to +71°C – Derating: 2.5 %/K above +50°C – Case temperature: +100°C max. – Storage: –40°C to +110°C
Humidity (non condensing)	85 % rel H max.
Reliability, calculated MTF (MIL-HDBK-217F, @ +25°C, ground benign)	>465'000h
Isolation voltage (60sec.)	– Input/Output: 1'500 VDC
Isolation capacity	– Input/Output: 235 pF typ.
Isolation resistance	– Input/Output (500 VDC): >100 M Ohm
Switching frequency (fixed)	330 kHz typ. (Pulse width modulation PWM)
Safety standards	UL 60950-1, IEC/EN 60950-1
Safety approvals	CSA File No. 226037 http://directories.csa-international.org
Remote On/Off	– On: open circuit on pin RC – Off: short circuit between pin RC and pin –Vin

Physical Specifications

Casing material	plastic PBT (UL94V-0 rated)
Baseplate	non conductive FR4
Potting material	silicon (UL94V-0 rated)
Weight	12 g (0.41 oz)
Soldering temperature	max. 265°C / 10sec.

Note 1

Recommended circuit to reduce conducted noise and output ripple & noise:

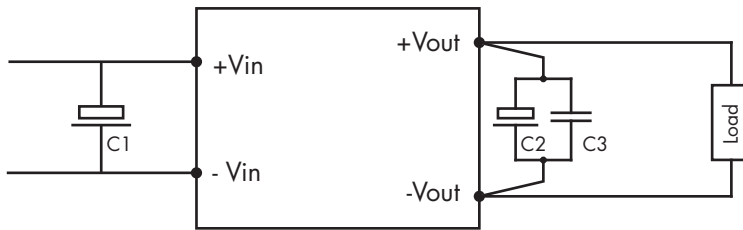

C1: 33µF low ESR electrolytic capacitor
C2: 10µF low ESR electrolytic capacitor
C3: 1µ film capacitor

For dual output models use capacitors for each output

Outline Dimensions mm

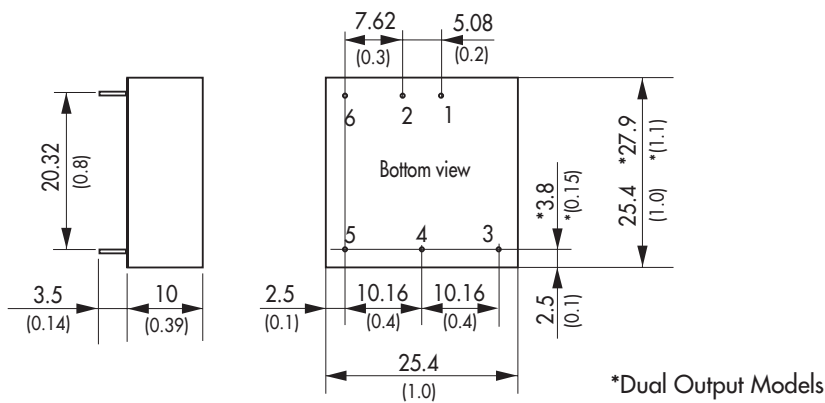

Pin-Out		
Pin	Single	Dual
1	+Vin (Vcc)	+Vin (Vcc)
2	-Vin (GND)	-Vin (GND)
3	+Vout	+Vout
4	No pin	Common
5	-Vout	-Vout
6	Remote On/Off	Remote On/Off

() = Inch

Pin diameter $\varnothing 0.8 \pm 0.05$ (0.02 \pm 0.002)
Tolerances ± 0.35 (± 0.014)

Specifications can be changed any time without notice.