

Features

- ◆ High power density in 1" x 2" metal package
- ◆ Ultra wide 4 : 1 input range
- ◆ Extended operating temperature range -40°C to +85°C max.
- ◆ No minimum load required
- ◆ I/O isolation 1500 VDC
- ◆ Remote On/Off
- ◆ Adjustable output voltage
- ◆ Industry standard footprint
- ◆ Shielded metal case with insulated baseplate
- ◆ Optional heatsink
- ◆ Lead free design - RoHS compliant
- ◆ 3-year product warranty



The TEN 20WIN series is a family of high performance 20W DC/DC converter modules featuring ultra wide 4:1 input voltage ranges in a ultra compact 2" x 1" low profile package with industry-standard footprint. A very high efficiency allows an operating temperature range of -40°C to 85°C. Further standard features include remote On/Off, output voltage trimming, over voltage protection and short-circuit protection.

Typical applications for these converters are battery operated equipment and distributed power architectures in communication and industrial electronics, everywhere where isolated, tightly regulated voltages are required.

Models

Order code	Input voltage range	Output voltage	Output current max.	Efficiency typ.
TEN 20-2410WIN	9 – 36 VDC (24 VDC nominal)	3.3 VDC	5'500 mA	85 %
TEN 20-2411WIN		5 VDC	4'000 mA	88 %
TEN 20-2412WIN		12 VDC	1'670 mA	86 %
TEN 20-2413WIN		15 VDC	1'330 mA	86 %
TEN 20-2421WIN		±5 VDC	±2'000 mA	88 %
TEN 20-2422WIN		±12 VDC	±835 mA	87 %
TEN 20-2423WIN		±15 VDC	±665 mA	87 %
TEN 20-4810WIN	18 – 75 VDC (48 VDC nominal)	3.3 VDC	5'500 mA	85 %
TEN 20-4811WIN		5 VDC	4'000 mA	88 %
TEN 20-4812WIN		12 VDC	1'670 mA	87 %
TEN 20-4813WIN		15 VDC	1'330 mA	87 %
TEN 20-4821WIN		±5 VDC	±2'000 mA	89 %
TEN 20-4822WIN		±12 VDC	±835 mA	88 %
TEN 20-4823WIN		±15 VDC	±665 mA	88 %

Input Specifications

Input current at no load	24 Vin models: 50 mA typ. 48 Vin models: 35 mA typ.
Input current at full load	24 Vin models: 1000 mA typ. 48 Vin models: 500 mA typ.
Surge voltage (100 msec. max.)	24 Vin models: 50 V max. 48 Vin models: 100 V max.
Input voltage variation (dv/dt)	5 V / ms, max. (complies to ETS 300 132 part. 4.4)
Start-up voltage / under voltage lockout	24 Vin models: 9 VDC / 7.5 VDC typ. 48 Vin models: 18 VDC / 15 VDC typ.
Conducted noise (input)	EN 55022 level A, FCC part 15, level A with external capacitor (see application note)
ESD (input)	EN 61000-4-2, perf. criteria B
Fast transient (input)	EN 61000-4-4, perf. criteria B
Surge (input)	EN 61000-4-5, perf. criteria B

Output Specifications

Voltage set accuracy	±1 %
Output voltage adjustment (single output models only)	±10 % by external resistor, see application note:
Regulation	<ul style="list-style-type: none"> – Input variation Vin min. to Vin max. 0.2 % max. – Load variation 0 – 100%: <ul style="list-style-type: none"> single output models: 0.5 % max. dual output models: 1 % max. (balanced load) – Load cross variation 25 % / 100 % 5 % max.
Temperature coefficient	0.02 %/K
Ripple and noise (20 MHz Bandwidth)	<ul style="list-style-type: none"> single output models: 75 mVpk-pk max. dual output models: 100 mVpk-pk max.
Start up time (nominal Vin and constant resistive load)	20 ms typ.
Transient Response (25% load step change)	250 µs typ.
Short circuit protection	indefinite (automatic recovery)
Over load protection	150 % of lout max typ.
Over voltage protection	<ul style="list-style-type: none"> 3.3 Vout models: 3.9 V 5 /±5 Vout models: 6.2 / ±6.2 V 12 /±12 Vout models: 15 / ±15 V 15 /±15 Vout models: 18 / ±18 V
Capacitive load	<ul style="list-style-type: none"> 3.3 Vout models: 18'000 µF max. 5 Vout models / ±5 Vout models: 9'600 µF max. / ±4'800 µF max. 12 Vout models / ±12 Vout models: 1'600 µF max. / ±800 µF max. 15 Vout models / ±15 Vout models: 1'000 µF max. / ±500 µF max.

General Specifications

Temperature ranges	<ul style="list-style-type: none"> – Operating –40°C to +85°C (see power derating) – Case temperature +105°C max. – Storage –55°C to +125°C
Humidity (non condensing)	95 % rel H max.

General Specifications

Reliability, calculated MTF (MIL-HDBK-217F at +25°C, ground benign)	>560'000 h
Isolation voltage (60 sec.) – Input/Output	1'500 VDC
Isolation capacitance – Input/Output	1500 pF max
Isolation resistance – Input/Output	>1'000 M Ohm
Switching frequency (fixed)	400 kHz typ. (pulse width modulation PWM)
Vibration	10-55Hz, 10G, 30 minutes along X,Y,Z
Remote On/Off – On: – Off: – Off idle current:	3.0 to 12 VDC or open circuit. 0 to 1.2 VDC or short circuit pin 2 and pin 6 2.5 mA typ.
Safety standards	UL 60950-1, EN/IEC 60950-1
Safety approvals – UL/cUL	www.ul.com -> certifications -> File E188913
Environmental compliance – Reach – RoHS	www.tracopower.com/products/ten20win-reach.pdf RoHS directive 2002/95/EC

Physical Specifications

Casing material	copper, nickel plated
Baseplate material	non conductive FR4
Potting material	epoxy (UL 94V-0 - rated)
Weight	27 g (0.95 oz)
Soldering temperature	max. 265°C / 10 sec.

Application note: www.tracopower.com/products/ten20win-application.pdf

Power Derating

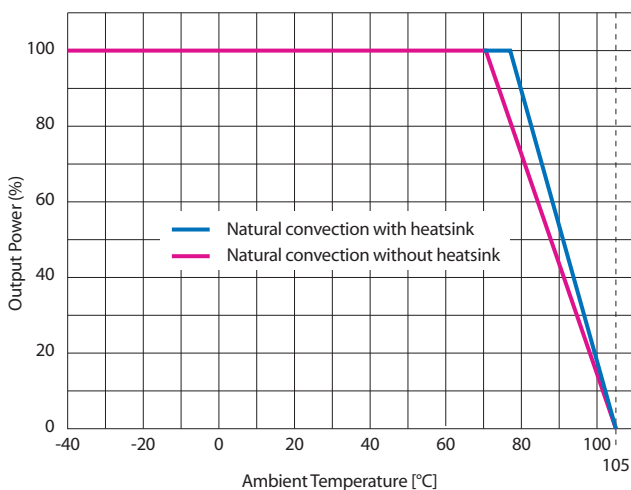

Outline Dimensions

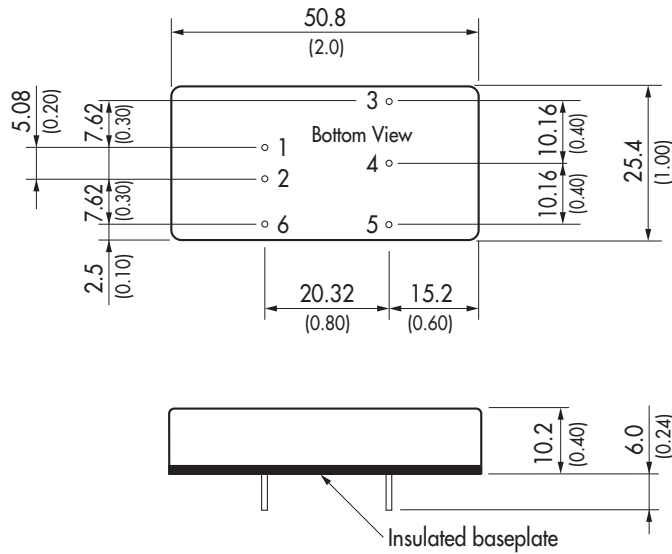

Pin-Out		
Pin	Single	Dual
1	+Vin (Vcc)	+Vin (Vcc)
2	-Vin (GND)	-Vin (GND)
3	+Vout	+Vout
4	Trim	Common
5	-Vout	-Vout
6	Remote On/Off	

Dimensions in [mm], () = Inch
 Pin diameter: 1.0 ±0.05 (0.039 ±0.002)
 Pin pitch tolerances: ±0.35 (±0.014)
 Case tolerances: ±0.5 (±0.02)

Heat-Sink (Option)

Order code: TEN-HS1
 (cont.: heat-sink, thermal pad, 2 clamps)
Material: Aluminum
Finish: Anodic treatment (black)
Weight: 17 g (0.60oz) without converter
 Thermal impedance after assembling: 10 K/W

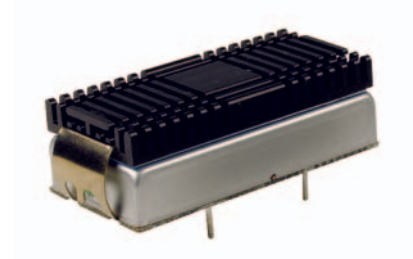

Note:
 The product label on converter has to be removed before mounting the heat-sink.
 For volume orders converters will be supplied with heat-sinks already mounted. Please contact factory for quotation.
 Separate heat-sinks are only available for prototypes and small quantity orders.

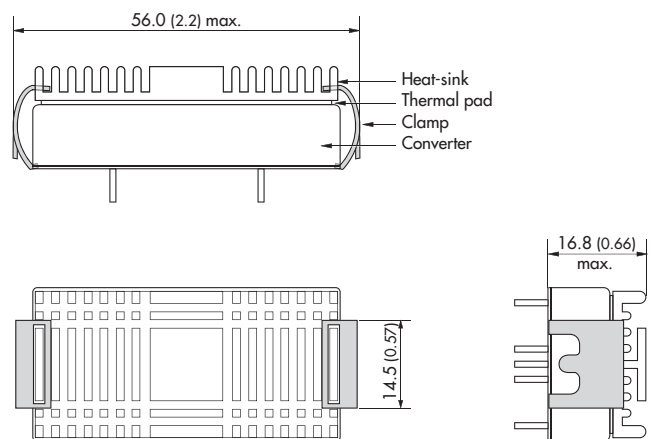

Specifications can be changed any time without notice.