

### Features

- ◆ Compact design in SMD or DIP package
- ◆ Ultra wide 4:1 input voltage range
- ◆ Fully regulated outputs
- ◆ Low ripple and noise
- ◆ No minimum load required
- ◆ Temperature range  $-40^{\circ}\text{C}$  to  $+85^{\circ}\text{C}$
- ◆ I/O isolation 1500 VDC
- ◆ Continuous short-circuit protection
- ◆ Remote On/Off control
- ◆ Fully RoHS compliant
- ◆ 3-year product warranty

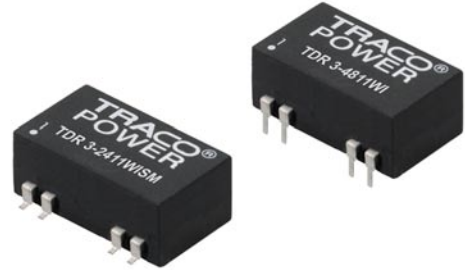

The TDR-3WI series is a family of compact 3 W dc/dc-converters with 4:1 input voltage ranges and tightly regulated output voltages even under no load conditions. The product is available in SMD-package or in DIP-package. They work with high efficiency over the full load range and come with a remote On/Off input.

The usability in temperature ranges of up to  $+85^{\circ}\text{C}$ , continuous short circuit protection and excellent immunity against environmental influences make these converters very reliable.

A TDR-3WI converter is the ideal solution for space critical high end applications in communication equipment, instrumentation and industrial electronics.

### Models

| Order code<br>DIP models | Order code<br>SMD models | Input voltage range              | Output voltage | Output current<br>max. | Efficiency typ. |
|--------------------------|--------------------------|----------------------------------|----------------|------------------------|-----------------|
| TDR 3-1211WI             | TDR 3-1211WISM           | 4.5 – 18 VDC<br>(12 VDC nominal) | 5.0 VDC        | 600 mA                 | 81 %            |
| TDR 3-1212WI             | TDR 3-1212WISM           |                                  | 12 VDC         | 250 mA                 | 82 %            |
| TDR 3-1213WI             | TDR 3-1213WISM           |                                  | 15 VDC         | 200 mA                 | 82 %            |
| TDR 3-1222WI             | TDR 3-1222WISM           |                                  | $\pm 12$ VDC   | $\pm 125$ mA           | 82 %            |
| TDR 3-1223WI             | TDR 3-1223WISM           |                                  | $\pm 15$ VDC   | $\pm 100$ mA           | 81 %            |
| TDR 3-2411WI             | TDR 3-2411WISM           | 9 – 36 VDC<br>(24 VDC nominal)   | 5.0 VDC        | 600 mA                 | 80 %            |
| TDR 3-2412WI             | TDR 3-2412WISM           |                                  | 12 VDC         | 250 mA                 | 82 %            |
| TDR 3-2413WI             | TDR 3-2413WISM           |                                  | 15 VDC         | 200 mA                 | 82 %            |
| TDR 3-2422WI             | TDR 3-2422WISM           |                                  | $\pm 12$ VDC   | $\pm 125$ mA           | 82 %            |
| TDR 3-2423WI             | TDR 3-2423WISM           |                                  | $\pm 15$ VDC   | $\pm 100$ mA           | 81 %            |
| TDR 3-4811WI             | TDR 3-4811WISM           | 18 – 75 VDC<br>(48 VDC nominal)  | 5.0 VDC        | 600 mA                 | 80 %            |
| TDR 3-4812WI             | TDR 3-4812WISM           |                                  | 12 VDC         | 250 mA                 | 83 %            |
| TDR 3-4813WI             | TDR 3-4813WISM           |                                  | 15 VDC         | 200 mA                 | 82 %            |
| TDR 3-4822WI             | TDR 3-4822WISM           |                                  | $\pm 12$ VDC   | $\pm 125$ mA           | 82 %            |
| TDR 3-4823WI             | TDR 3-4823WISM           |                                  | $\pm 15$ VDC   | $\pm 100$ mA           | 81 %            |

### Input Specifications

|   |  |
|---|--|
| Input current at no load (nominal input voltage)                        | 12 Vin models: 40 mA typ.<br>24 Vin models: 20 mA typ.<br>48 Vin models: 13 mA typ.  |
| Input current at full load (nominal input voltage)                      | 12 Vin models: 330 mA typ.<br>24 Vin models: 165 mA typ.<br>48 Vin models: 80 mA typ.  |
| Surge voltage (1 sec. max.)   | 12 Vin models: 25 V max.<br>24 Vin models: 50 V max.<br>48 Vin models: 100 V max.  |
| Input filter  | capacitor type (see EMC considerations page 3 for compliance to EN 55022 class A/B)  |
| ESD (electrostatic discharge)   | EN 61000-4-2, air ±8 kV, contact ±6 kV, perf. criteria A   |
| Radiated immunity   | EN 61000-4-3 10 V/m, perf. criteria A  |
| Fast transient / Surge  | EN 61000-4-4, ±2 kV, perf. criteria A<br>EN 61000-4-5, ±1 kV perf. criteria A<br>with external input capacitor e.g. Nippon chemi-con KY 220 µF, 100 V, ESR 48 mOhm |
| Conducted immunity  | EN 61000-4-6, 10 Vrms, perf. criteria A  |
| Reflected ripple current (measured with input filter according class A) | 12 Vin models: 80 mA <sub>p-p</sub> typ.<br>24 Vin models: 40 mA <sub>p-p</sub> typ.<br>48 Vin models: 30 mA <sub>p-p</sub> typ.                                   |

### Output Specifications

|   |   |
|---|---|
| Voltage set accuracy                                    | ±1 % max  |
| Regulation  | – Input variation Vin min. to Vin max. 0.2 % max.<br>– Load variation 0 – 100 % single output models: 1.0 % max.<br>dual output models: 1.0 % max. balanced load<br>– Load variation 10 – 90 % single output models: 0.5 % max.<br>dual output models: 0.8 % max. balanced load<br>– Load cross regulation 25/100 % 5.0 % max. (dual output models) |
| Minimum load  | 0 % of rated max. load  |
| Temperature coefficient                                 | ±0.02 %/K   |
| Ripple and noise (20 MHz bandwidth)                     | 30 mV <sub>p-p</sub> typ.   |
| Start up time (constant resistive load)                 | – Power On 5 ms typ.<br>– Remote On 5 ms typ.   |
| Transient response setting time (25 % load step change) | 250 µs typ.   |
| Short circuit protection                                | indefinite, automatic recovery  |
| Capacitive load   | 5 VDC models: 1680 µF max.<br>12 VDC models: 820 µF max.<br>15 VDC models: 680 µF max.<br>±12 VDC models: ±470 µF max.<br>±15 VDC models: ±330 µF max.  |

All specifications valid at nominal input voltage, full load and +25°C after warm-up time unless otherwise stated.

**General Specifications**

|  |   |  |
|--|---|--|
| Temperature ranges   | - Operating<br>- Storage                        | -40°C to +85°C<br>-55°C to +125°C  |
| Load derating  |   | 3.3 %/K above +70°C  |
| Humidity (non condensing)  |   | 5 % to 90 % rel. H max.  |
| Thermal shock  |   | acc. MIL-STD-810F  |
| Vibration  |   | acc. MIL-STD-810F  |
| Reliability, calculated MTTF (MIL-HDBK-217F, @ +25°C, ground benign) |   | >2.0 Mio h   |
| Isolation voltage (60 sec.)  | - Input/Output                                  | 1500 VDC   |
| Isolation capacitance  | - Input/Output                                  | 50 pF max.   |
| Isolation resistance   | - Input/Output (500 VDC)                        | >10 GOhm   |
| Safety standard (designed to meet)                                   |   | IEC/EN 60950-1, UL 60950-1   |
| Switching frequency  |   | 100 kHz (PWM)  |
| Remote On/Off  | - On:<br>- Off:<br>- Off stand by input current | open or high impedance<br>2...4 mA current applied via 1KOhm resistor<br>2.5 mA max. |

**EMC Consideration**

Recommended filter for  
**EN 55022 class A** compliance

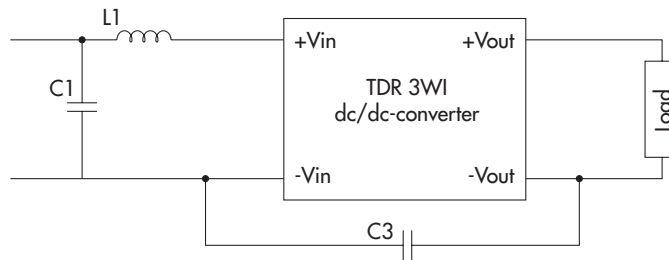

| Input models | C1                       | C3                     | L1 value | order code (SMD type) | datasheet:   |
|--------------|--------------------------|------------------------|----------|-----------------------|--|
| 12 VDC       | 4.7 µF / 25 V 1812 MLCC  | 220pF / 3 kV 1808 MLCC | 10 µH    | <b>TCK-047</b>        | <a href="http://www.tracopower.com/products/tck047.pdf">www.tracopower.com/products/tck047.pdf</a> |
| 24 VDC       | 4.7 µF / 50 V 1812 MLCC  |                        | 12 µH    | <b>TCK-062</b>        | <a href="http://www.tracopower.com/products/tck062.pdf">www.tracopower.com/products/tck062.pdf</a> |
| 48 VDC       | 4.7 µF / 100 V 1812 MLCC |                        | 10 µH    | <b>TCK-047</b>        | <a href="http://www.tracopower.com/products/tck047.pdf">www.tracopower.com/products/tck047.pdf</a> |

Recommended filter for  
**EN 55022 class B** compliance

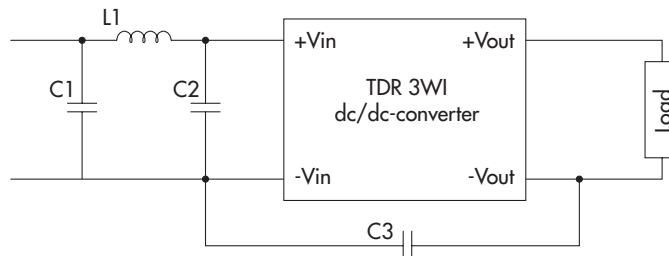

| Input models | C1 & C2                  | C3                     | L1 value | order code (SMD type) | datasheet:   |
|--------------|--------------------------|------------------------|----------|-----------------------|--|
| 12 VDC       | 6.8 µF / 25 V 1812 MLCC  | 220pF / 3 kV 1808 MLCC | 10 µH    | <b>TCK-047</b>        | <a href="http://www.tracopower.com/products/tck047.pdf">www.tracopower.com/products/tck047.pdf</a> |
| 24 VDC       | 4.7 µF / 50 V 1812 MLCC  |                        | 12 µH    | <b>TCK-062</b>        | <a href="http://www.tracopower.com/products/tck062.pdf">www.tracopower.com/products/tck062.pdf</a> |
| 48 VDC       | 4.7 µF / 100 V 1812 MLCC |                        | 18 µH    | <b>TCK-046</b>        | <a href="http://www.tracopower.com/products/tck046.pdf">www.tracopower.com/products/tck046.pdf</a> |

All specifications valid at nominal input voltage, full load and +25°C after warm-up time unless otherwise stated.

**Physical Specifications**

|  |  |
|--|--|
| Casing material  | non-conductive plastic (UL94V-0 rated)   |
| Package weight   | 4.5 g (0.16 oz)  |
| Soldering profile for DIP-package models               | max. 265°C / 10 sec. (wave soldering)  |
| Lead-free reflow solder process for SMD-package models | as per J-STD-020D.01 (to find at:<br><a href="http://www.jedec.org">www.jedec.org</a> - free registration required)          |
| Moisture sensivity level (for SMD-package models)      | level 2a as per J-STD-033B.01 (to find at:<br><a href="http://www.jedec.org">www.jedec.org</a> - free registration required) |

**Outline Dimensions**

**DIP-Models**

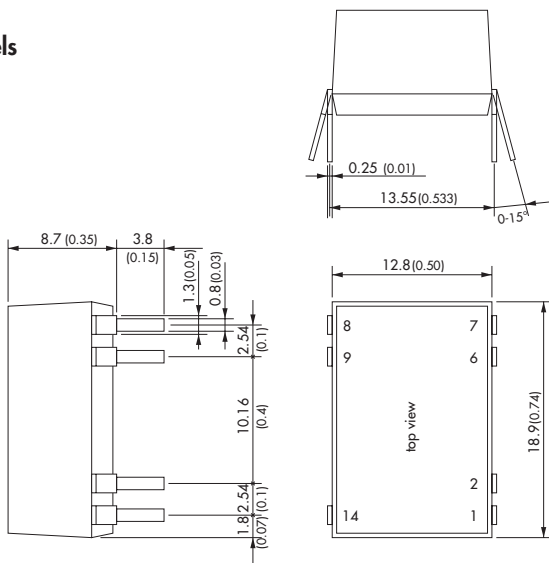

| Pin-Out |               |               |
|---------|---------------|---------------|
| Pin     | Single        | Dual          |
| 1       | -Vin (GND)    | -Vin (GND)    |
| 2       | Remote On/Off | Remote On/Off |
| 6       | NC            | Common        |
| 7       | NC            | -Vout         |
| 8       | +Vout         | +Vout         |
| 9       | -Vout         | Common        |
| 14      | +Vin (Vcc)    | +Vin (Vcc)    |

NC = not to connect

**SMD-Models**

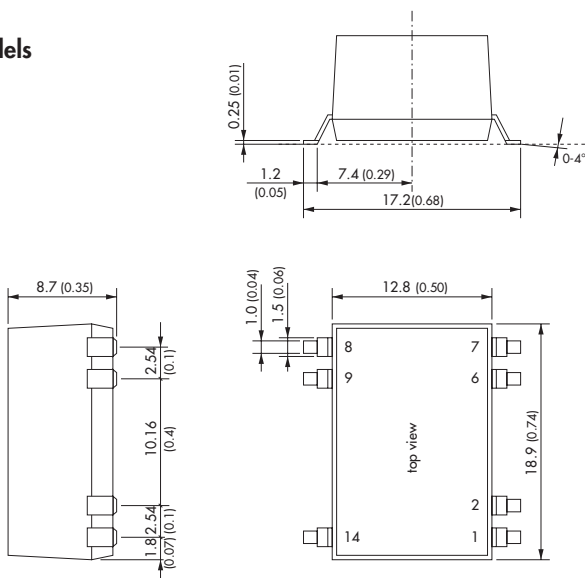

**Recommended Solder Pad Dimension:**

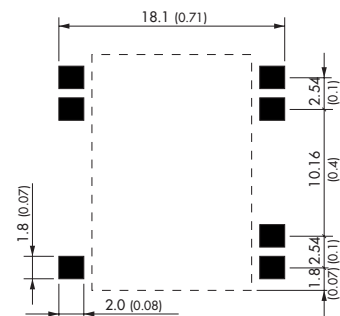

Dimensions in [mm], ( ) = Inch  
Tolerances: ±0.5 (±0.02)  
Pin pitch tolerances: ±0.25 (±0.01)

Specifications can be changed any time without notice.