



Features

- ◆ Uninterruptible switch mode power supply for DIN-rail mount
- ◆ Battery management system included
- ◆ Uninterrupted 24 VDC / 60 W
- ◆ UL 508 listed
- ◆ For Alarm equipment compliant EN 50131
- ◆ External battery size free selectable
- ◆ Adjustable output voltage
- ◆ Short circuit and overload protection
- ◆ Easy snap-on mounting on DIN-rail
- ◆ 3-year product warranty



The TBL-BC power supply is a uninterruptible DIN-Rail switch mode power supply designed for application in alarm equipment, building automation or other security relevant systems. It guarantees continued operation in the case of a mains power failure.

The unit charges the external battery at an optimum charge voltage to suit the battery temperature using an external NTC temperature sensor. An alarm output will indicate if there is a problem with the battery voltage, the battery temperature or the mains input voltage.

Models

| Order Code | Output Power (max.) | Output Voltage* (nom.) | Output Current ** (max.) | Efficiency (typ.) |
|---------------|------------------------|---------------------------|-----------------------------|----------------------|
| TBL 060-124BC | 60 W | 24 VDC | 2.2 A | 84 % |

* The Battery charging voltage is factory set to 27,6 VDC at 25°C

** reduce max. output current by battery charging current

Input Specifications

| | | |
|------------------------------|------------------------------|--|
| Input voltage | - nominal - AC auto range | 100 – 120 / 220 – 240 VAC 85 – 132 / 187 – 264 VAC |
| Input frequency | | 47 – 63 Hz |
| Input current (at full load) | | V _{in} = 115 VAC V _{in} = 230 VAC 1.4 A typ. 0.7 A typ. |
| Harmonic limits | | EN 61000-3-2, Class A |

Output Specifications

| | | |
|---------------------------|--|---|
| Output voltage adj. range | | 26.0 – 29.5 VDC, factory set: 27.6 VDC at 25°C |
| Voltage drift (see graph) | | -54 mV/°C - maximum voltage at -10°C: 29.5 VDC - minimum voltage at +55°C: 26.0 VDC |

Output voltage vs battery temperature

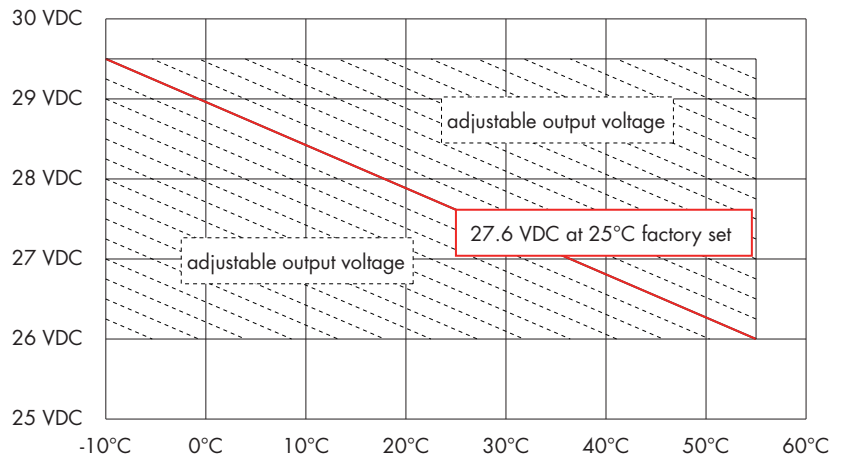

| | | |
|---------------------------------------|--|--|
| Output current max. | | 2.2 A - Reduce output power by desired battery charging current. Maximum output power must not exceed 60 W |
| Ripple and noise (20MHz bandwidth) | | <50 mV pk-pk |
| Overload and short circuit protection | | current limitation at 2.5 A constant current (automatic recovery) applies to both, load and battery charge output |
| Overvoltage protection | | at 31,2 V |
| Voltage difference at mains failure | | 0.3 V typ. (max 1.0 V for 1 sec.) |
| Regulation | - Input variation - Load variation (10–100 %) | 0.04 % max. 0.2 % max. |
| Signal output | | Open collector 60 VDC max., 35 mA max. sink current |

| LED indicator | Signal output | Status | Condition |
|----------------|---------------|--------------------------|--|
| Constant green | closed | Mains and battery ok | |
| Flash green | open | Mains fail, battery ok | Input voltage below 80 VAC, power from battery |
| Constant red | open | Battery voltage fail | Battery voltage below 23.8 VDC (activation range: 23.2 – 24.4) |
| Flash red | open | Battery temperature fail | Battery temperature exceeded 65°C (or temperature sensor connection is open or short circuited) |

General Specifications

| | | |
|--|---|--|
| Temperature ranges | <ul style="list-style-type: none"> - Operating - Storage (non operating) | <p>-10°C to +55°C max. -20°C to +70°C</p> |
| Power derating | | 2.5 %/K above +50°C |
| Humidity (non condensing) | | 99 % rel. H |
| Switching frequency | | 70 kHz typ. (fixed) |
| Isolation | | according to IEC/EN 60950-1, UL 60950-1, UL 508 |
| Safety standards | <ul style="list-style-type: none"> - Information technology equipment - Industrial control equipment - Electrical equipment for machines - Electronic equipment for power installation - Transformer safety for bell and chime transformers - Transformer safety for switch mode power supplies | <p>IEC/EN 60950-1, UL 60950-1 UL 508 EN 60204-1 EN 50178 EN 61558-2-8 EN 61558-2-17</p> |
| Safety approvals | | in progress |
| Electromagnetic compatibility (EMC), emissions | <ul style="list-style-type: none"> - Conducted RI suppression on input - Radiated RI suppression | <p>EN 61000-6-3 /EN 61000-6-4 EN 55011 class B, EN 55022 class B EN 55011 class A, EN 55022 class A</p> |
| Electromagnetic compatibility (EMC), immunity | <ul style="list-style-type: none"> - Electrostatic discharge (ESD) - Radiated RF field immunity - Electrical fast transient / burst immunity - Surge immunity line – ground - Surge immunity line – line - Surge immunity output - Immunity to conducted RF disturbances - Power frequency field immunity | <p>EN 61000-6-2 EN54-4, EN 50130-4 EN54-4, EN 50130-4 EN54-4, EN 50130-4 IEC/EN 61000-4-5 2 kV IEC/EN 61000-4-5 1 kV IEC/EN 61000-4-5 0.5 kV IEC/EN 61000-4-6 10 V IEC/EN 61000-4-8 30 A/m</p> |
| Protection class | | class II as per IEC/EN 61140 |
| Case protection | | IP 20 (IEC 60529) |
| Environment | <ul style="list-style-type: none"> - Vibration acc. IEC 60068-2-6; - Shock acc. IEC 60068-2-27 | <p>3 axis, sine sweep, 10 – 55 Hz, 0.075 mm 3 axis, 15 g half sine, 11 ms</p> |
| Enclosure material | | plastic FR2010-110C (UL 94V-0 rated) |
| Mounting | | DIN-rails as per EN 50022-35x15/7.5 (snap-on with self-locking spring) |
| Connection | | screw terminals with combi-type screw heads for wire size 0.5 – 1.5 mm ² |
| Installation instructions | | in progress |

Battery Supervision & UPS Function

| | |
|---|--|
| Under voltage lockout (VuVL) | 21.0 - 22,5 VDC, Battery will be disconnected if it is short circuited or voltage drops below VuVL (As a battery can artificially recover itself, it will remain disconnected until mains recover) |
| Active battery test - draws 1.2 A during 2 sec. | at battery voltage: >25.5 VDC Battery voltage fail, if voltage drops below 23.8 VDC during this test |
| Passive battery test - draws no current | at battery voltage: VuVL – 25.5 VDC Battery voltage fail, if voltage is below 23.8 V |
| Test routine | 2 sec. every 60 sec. only if mains is ok |
| Battery temperature supervision | NTC: K164/4.7k/K, Siemens Matsushita: B57164-K472-K |
| Battery charge characteristics | I-V curve |

In the transition from mains to battery operation and vice versa, the output is not interrupted and the difference between Battery Voltage (V_{batt}) and Output Voltage (V_o) is typically no more than 0.3 V. To optimize battery charging, the battery charging voltage is adjusted to suit the battery temperature by means of an NTC temperature sensor which must be placed near the battery. The charge voltage falls with increasing temperature. The unit incorporates full automatic monitoring for the presence and condition of the battery. Two different battery tests are carried out (passive or active) depending on the battery voltage. Both types of test are carried out once every 60 seconds and the tests last ~2 seconds. If the battery voltage is between ~21.4V and ~25.5V a passive battery test is carried out which only tests the battery voltage but does not draw any current from the battery. Between 25.5V and the maximum battery voltage, an active battery test is carried out in which a current of ~1.2A is drawn from the battery through an internal load for ~2s. If the battery voltage is determined to be

below ~23.8 V after any of these tests, then a battery fail notification is given. The battery tests are only carried while the mains voltage is ok. The unit also produces a failure notification in the event of a disconnected or short-circuited battery. In the event of a battery failure in any of these modes, the LED will turn constant RED and a built in open-Collector circuit stops sinking current from to the FAIL output pin. In the case of a mains fail, if the battery voltage is detected to be below ~21V min. then it is automatically disconnected from the load to prevent a deep-discharge and subsequent long-term damage to the battery. Note that after it has disconnected, the battery voltage may rise above 21V once more, however in this case, the switch will not open again as the battery has not truly recovered. The switch will not open again until the mains has recovered and the battery then goes straight into charge mode. The input terminals »L« and »N«, the output terminals «+24V», «OV», «+BATT» and «FAIL» and the temperature sensor terminals «S1» and «S2» are clearly marked on the hood label.

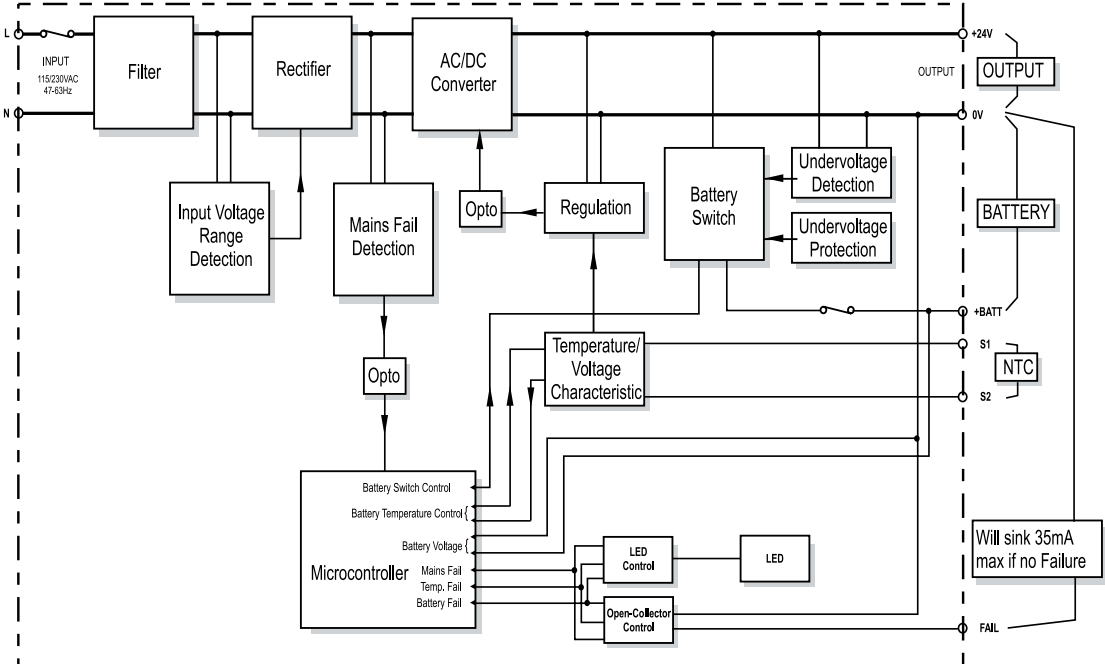

Case Dimensions

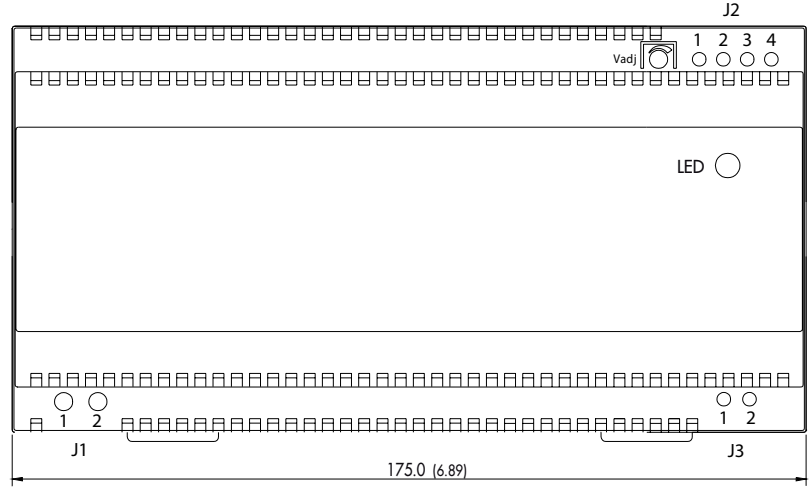
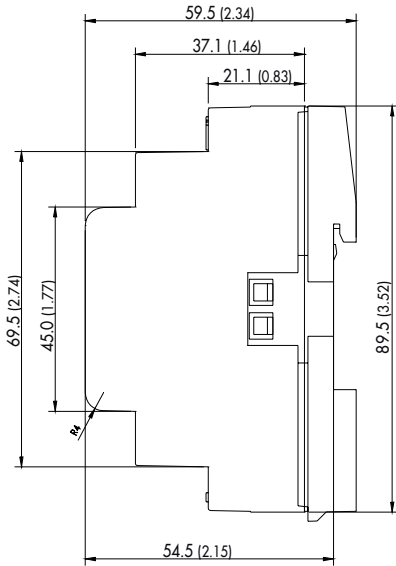

Weight: 410 g (14.46 oz)

Dimensions in [mm], () = Inch
Tolerances: ±0.5 mm (±0.02)

| J1 (input) | |
|------------|--------|
| 1 | AC (L) |
| 2 | AC (N) |

| J2 (output) | |
|-------------|----------|
| 1 | +Vout |
| 2 | GND (0V) |
| 3 | +Batt |
| 4 | Fail |

| J3 (temp. sense) | |
|------------------|----|
| 1 | S1 |
| 2 | S2 |

Battery Temperature Sensor - not included

| Order code | Description | NTC Model |
|------------|---|-----------------------------------|
| TBL-BC-TS1 | Battery sensor (NTC) with 2 m connection line | Siemens Matsushita: B57164-K472-K |

Specifications can be changed any time without notice.