

SIP SMT20W-12

S E R I E S

20 AMP POL CONVERTERS

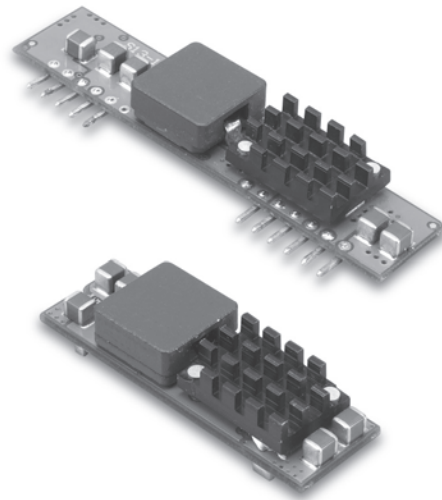

Features

- Non-Isolated POL Converter
- SIP / SMT Package
- Output Current 20AMP
- Input Voltage Range 6-14VDC
- Output Voltage Range 0.7525-5VDC
- 300KHz Switching Frequency
- High Efficiency to 94%
- Over Temperature Protection
- Continuous Short Circuit Protection
- Remote On/Off Control
- Output Voltage Sequencing
- Power Good Signal
- UL/c-UL 60950 Certified

MODEL NUMBER	INPUT VOLTAGE	OUTPUT VOLTAGE	OUTPUT CURRENT	INPUT CURRENT		% EFF.
				NO LOAD	FULL LOAD	
SIP 20W-12S05A	6.0-14VDC	0.7525VDC	20A	40mA	1603mA	78
	6.0-14VDC	1.2VDC	20A	50mA	2381mA	84
	6.0-14VDC	1.5VDC	20A	50mA	2874mA	87
	6.0-14VDC	1.8VDC	20A	50mA	3409mA	88
SMT20W-12S05A	6.0-14VDC	2.0VDC	20A	60mA	3745mA	89
	6.0-14VDC	2.5VDC	20A	65mA	4630mA	90
	6.0-14VDC	3.3VDC	20A	75mA	5978mA	92
	6.5-14VDC	5.0VDC	20A	95mA	8865mA	94

NOTE: 1. Nominal Input Voltage 12VDC

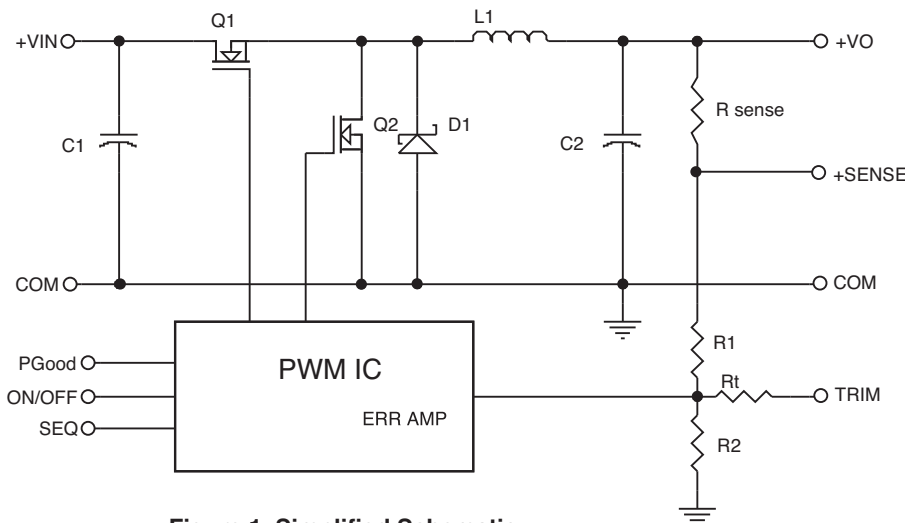

Figure 1. Simplified Schematic

Vo, set (V)	Rtrim (KΩ)
0.7525	Open
1.2	22.46
1.5	13.05
1.8	9.024
2.0	7.417
2.5	5.009
3.3	3.122
5.0	1.472

Table 1. External Resistor Values for programming output voltage

Specifications

INPUT SPECIFICATIONS:

Input Voltage Range.....12V.....	6.0 – 14V
.....12V.....	6.5 – 14V
Under Voltage Lock-out	Power up5.0V Typ.
.....	Power down.....4.0V Typ.
Input Filter Type.....	Capacitive
Positive Remote on/off Control :	
Module ON.....	Open Circuit or = Vin
Module OFF.....	< 0.4 Vdc

OUTPUT SPECIFICATIONS:

Voltage Accuracy.....	±1.5% max.
Transient Response :25% Step Load Change.....	<200µ sec.
Ripple and Noise, 20MHz BW ³	30mV rms max.
.....	75mV pk-pk max.
Temperature Coefficient.....	±0.03%/C max.
Short Circuit Protection.....	Continuous
Line Regulation ¹	± 0.2% max.
Load Regulation ²	± 0.5% max.
External Trim Adj. Range (see Table 1).....	Vo=0.75-5.0Vdc
Sequencing Slew Rate Capability (dV _{seq} /dt).....	0.1-1.0V/msec
Sequencing Delay Time.....	10msec min.
Tracking Accuracy.....	Power up.....200mV max.
.....	Power down.....400mV max.
Capacitive Load, Low ESR.....	8000µF max.
Power Good Signal Asserted Logic High.....	Vo=90%-100%Vo,nom

GENERAL SPECIFICATIONS:

Efficiency.....	See Table
Isolation Voltage.....	Non-isolation
Switching Frequency	300KHz Typ.
Over Temperature Protection	130°C Typ.
Operating Ambient Temperature Range.....	-40°C to +85°C
Power Derating Curve	see Figure 2,3
Storage Temperature Range	-55°C to +125°C
Dimensions:	
SIP Package:	2.40 x 0.510 x 0.327 inches (61.0 x 12.95 x 8.3 mm)
SMT Package:	1.70 x 0.530 x 0.366 inches (43.2 x 13.46 x 9.3 mm)
Structure.....	Non-potted With Open Frame Type
Weight.....	1g

SIP20W-12S05A Vo=3.3V Derating Curve

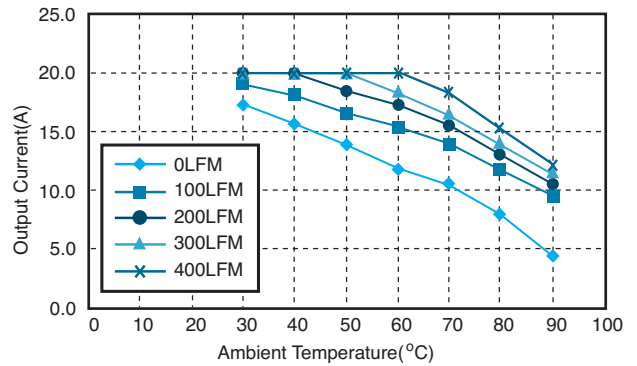

Figure 2. Typical Power De-rating for 12V IN

SMT20W-12S05A Vo=3.3V Derating Curve

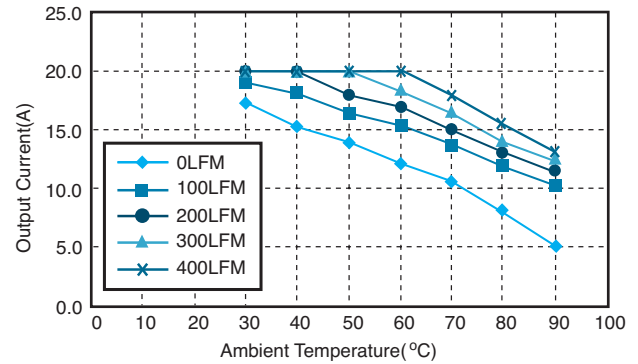

Figure 3. Typical Power De-rating for 12V IN

NOTE:

1. Measured From High Line to Low Line, Vo,set=3.3Vdc
2. Measured From Full Load to Zero Load, Vo,set=3.3Vdc
3. The output noise is measured with 10µf tantalum capacitor and 1µf ceramic capacitor across output.
4. The Input Terminal Recommend to Parallel With 200µF Capacitor ESR<25mΩ to Reduce The Input Ripple Voltage
5. Suffix "N" to the Model Number with Negative Logic Remote on/off
 Model ON.....Open Circuit or < 0.4VDC
 Module OFF.....>+2.8VDC to Vin
6. Suffix "P" to the Model Number with Power Good function.

Mechanical Specification

All Dimensions In Inches(mm)
 Tolerance Inches: x.xx= ±0.02, x.xxx= ±0.010
 Millimeters: x.x= ±0.5, x.xx= ±0.25

SIP Packages

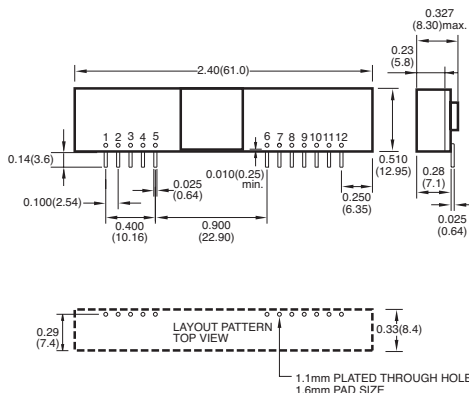

PIN CONNECTION

Pin	Function
1	+Output
2	+Output
3	+Sense
4	+Output
5	Common
6	No Pin / PGood
7	Common
8	+V Input
9	+V Input
10	Sequency
11	Trim
12	On/Off Control

SMT Packages

BOTTOM VIEW OF BOARD

