



Features :

- Universal AC input / Full range
- Auto switch when power off (UPS function)
- Built-in constant current limiting circuit
- Alarm signal for AC OK and Battery low (TTL open collector output or Relay contact output)
- Protections: Short circuit / Over load / Over voltage
Brown-out (Low AC Input Voltage)
Battery low protection
Battery polarity protection
(by Resettable Fuses)
- Cooling by free air convection
- High efficiency, long life and high reliability
- Withstand 2G vibration test
- All using 105°C long life electrolytic capacitors
- 3 years warranty



MODEL		QE-100-G		QE-100-GB			QE-100-L		QE-100-LB			
Output	Output Number	CH1	CH2	CH1	CH2	CH3	CH1	CH2	CH1	CH2	CH3	
	DC Voltage Range	13.8V	13.8V	13.8V	13.8V	5V	27.6V	27.6V	27.6V	27.6V	5V	
	Rated Current	5.3A	2A	4.2A	2A	3A	2.15A	1.5A	1.6A	1.5A	3A	
	Current Range	0~5.2A	-----	0~5.2A	-----	0~3.2A	0~2.6A	-----	0~2.6A	-----	0~3.2A	
	Rated Power	100.74W		100.56W			100.74W		100.56W			
	Ripple & Noise (max.)	100mV	-----	100mV	-----	100mV	100mV	-----	100mV	-----	100mV	
	Voltage Adj. Range	CH1:10%					CH1:10%					
	Voltage Tolerance	±1%	-----	±1%	-----	±3%	±1%	-----	±1%	-----	±3%	
	Line Regulation	±0.5%	-----	±0.5%	-----	±0.5%	±0.5%	-----	±0.5%	-----	±0.5%	
	Load Regulation	±0.5%	-----	±0.5%	-----	±1%	±0.5%	-----	±0.5%	-----	±1%	
	Setup, Rise Time	800ms, 30ms/230VAC 800ms, 30ms/115VAC at full load										
Hold up Time (Typ.)	50ms / 230VAC		10ms / 115VAC at full load									
Input	Voltage Range	90 ~ 264VAC		127 ~ 373VDC								
	Frequency Range	47Hz ~ 63Hz										
	Efficiency (Typ.) at 230Vac	86%			85%			87%		85%		
	AC Current (Typ.)	2A / 115VAC		1.2A / 230VAC								
	Inrush Current (Typ.)	Cold Start 35A / 115VAC 70A / 230VAC (Withstand 300VAC surge for 5sec. Without damage)										
Leakage Current	For earth <1mA / 264VAC											
Protection	Over Load	Above 110% rated output power Protection type : Hiccup mode, recovers automatically after fault condition is removed										
	Over Voltage	115% ~ 140% rated output voltage Protection type : latch-off mode										
	Battery cut off	10V±5%					20V±5%					
Function	AC OK	TTL open collector output		Relay contact output			TTL open collector output		Relay contact output			
	BAT Low	Battery low voltage <12V±3%					Battery low voltage <22V±3%					
Environment	Working Temp.	-20°C ~ +70°C (Refer to output load de-rating curve)										
	Working Humidity	20 ~ 90% RH non-condensing										
	Storage Temp., Humidity	-40 ~ +85°C, 20 ~ 90%										
	Temp. Coefficient	±0.03%/°C (0 ~ 50°C) on CH1										
	Vibration	10 ~ 500Hz, 2G 10min./1 cycle, period for 60 min. each along X,Y,Z axes										
Safety & EMC	Safety Standards	Meet UL60950-1 / TUV EN60950-1 Approved										
	Withstand Voltage	I/P - O/P : 3KVAC I/P - FG : 1.5KVAC O/P-FG : 0.5KVAC										
	Isolation Resistance	I/P - O/P: 100M Ω / 500VDC										
	EMI Conduction & Radiation	EN55022 : 2006+A1:2007 Class B										
	Harmonic Current	EN61000-3-2 : 2006 Class A, EN61000-3-3 : 1995+A1 : 2005										
EMS Immunity	EN61000-4-2,3,4,5,6,8,11; ENV50204; EN55024											
Others	MTBF											
	Dimension (L*W*H)(mm)	129.5x97.5x37.5mm										
Packing												
Note	1. All parameters NOT specially mentioned are measured at 230VAC input, rated load and 25°C of ambient temperature. 2. Ripple & noise are measured at 20MHz of bandwidth by using a 12" twisted pair-wire terminated with a 0.1uf & 47 uf parallel capacitor. 3. Tolerance: includes set up tolerance, line regulation and load regulation. 4. Line regulation is measured from low line to high line at rated load. 5. Load regulation is measured from 0% to 100% rayed load. 6. The power supply is considered a component which will be installed into a final equipment. The final equipment must be re-confirmed that it still meets EMC directives. 7.Length of aet up time is measured at cold first start. Turning ON/OFF the power supply very quickly may lead to increase of the set up time.											

Mechanical Specification

Unit:mm

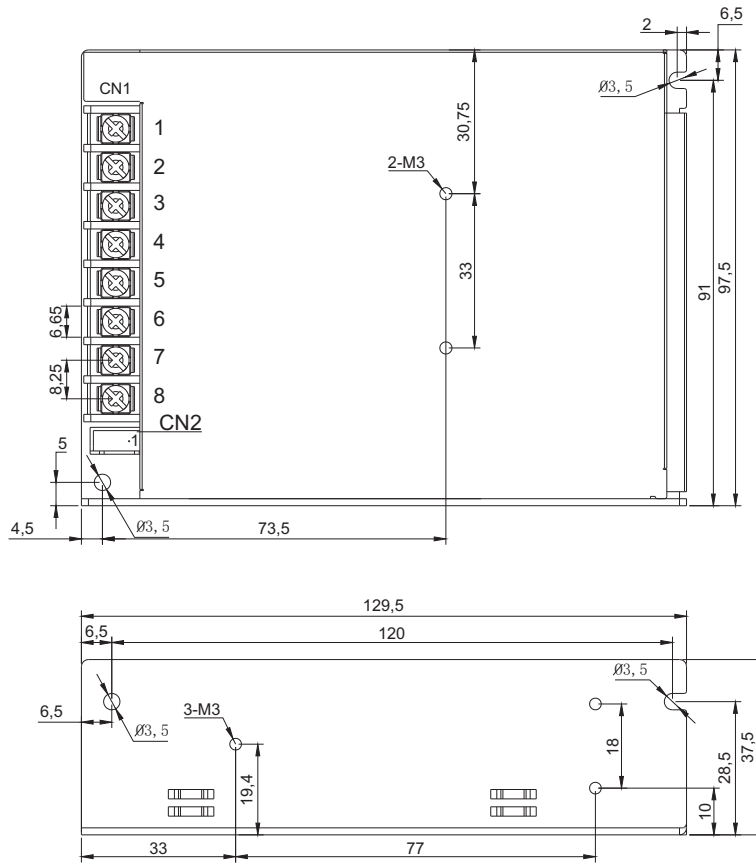

Terminal Pin No. Assignment(CN1)

Pin No.	Assignment	Pin No.	Assignment
1	AC/L	5	DC output VO+
2	AC/N	6	BAT+
3	FG \perp	7	BAT-
4	DC Output GND	8	DC/DC Output +5V (GB/LB only)

QE-75-G/L

Alarm output Connector(CN2): JST B3B-XH or equivalent

Pin No.	Assignment	Mating Housing	Terminal
1	AC OK	JST XHP-3 or equivalent	JST SXH-001 T-P0.6 or equivalent
2	BAT LOW		
3	G (13.8V/20mA) L (27.6V/20mA)		

QE-75-GB/LB

Alarm output Connector(CN2): JST B4B-XH or equivalent

Pin No.	Assignment	Mating Housing	Terminal
1 2	AC OK	JST XHP-4 or equivalent	JST SXH-001 T-P0.6 or equivalent
3 4	Bat. Low		

Mechanical Specification

Output Derating VS Input Voltage

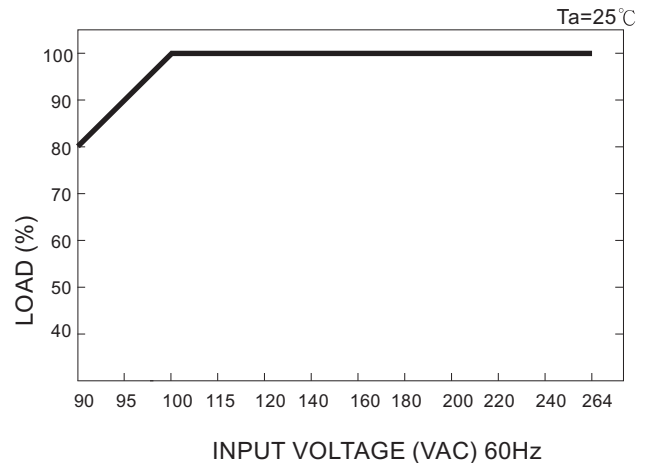
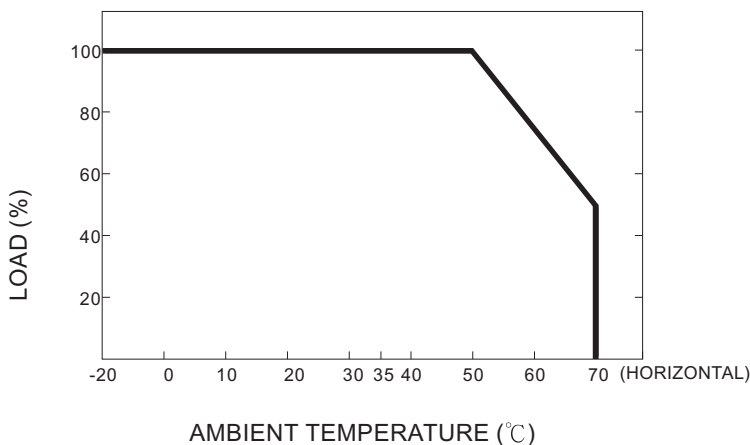

■ For QE-100-G/L

■ Block Diagram

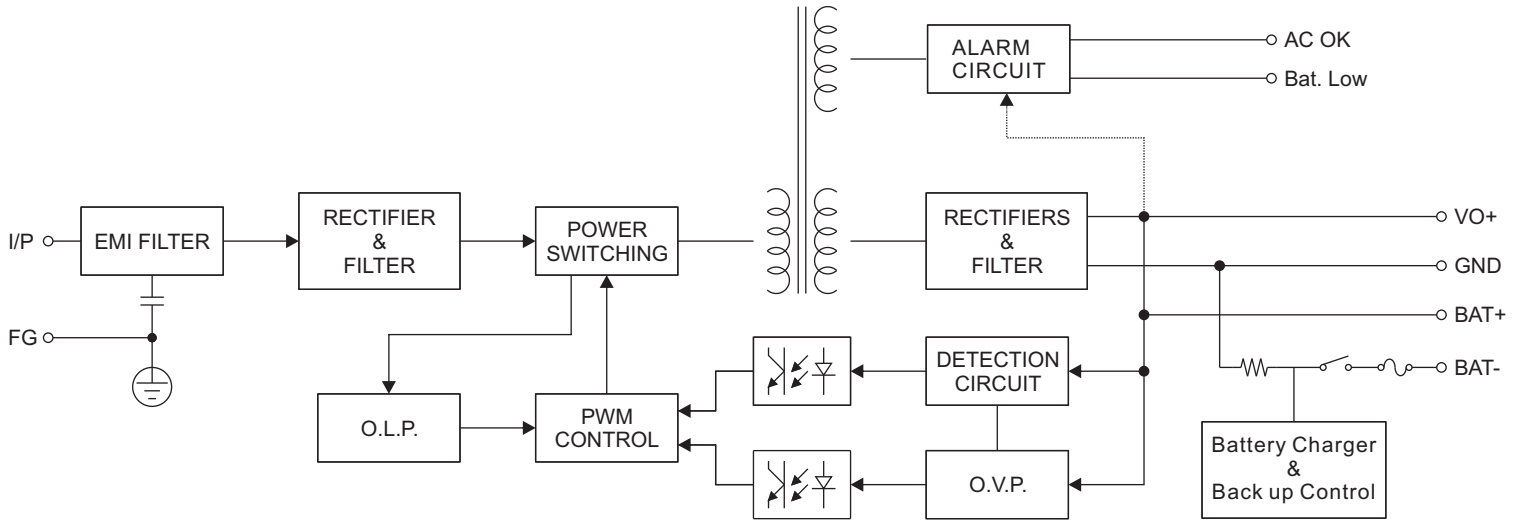

■ Alarm Signal for AC OK and Battery Low

- (1) Alarm Signal is sent out through "AC OK" & "Battery Low" pins.
- (2) An external voltage source is required for this function. The maximum applied voltage is 50V and the maximum sink current is 30mA.
- (3) Table 3.1 explain the alarm function built-in the power supply

Function	Description	Output of alarm
AC OK	The signal is "Low" when the power supply turns on	Low (0.3V max. at 30mA)
	The signal turns to be "High" when the power supply turns OFF	High or open(External applied voltage 30mA max.)
Battery Low	The signal is "Low" when the voltage of battery is under G:12V , L:22V	Low (0.3V max. at 30mA)
	The signal is "High" when the voltage of battery is above G:12V , L:22V	High or open(External applied voltage 30mA max.)

Table 3.1 Explanation of Alarm Signal

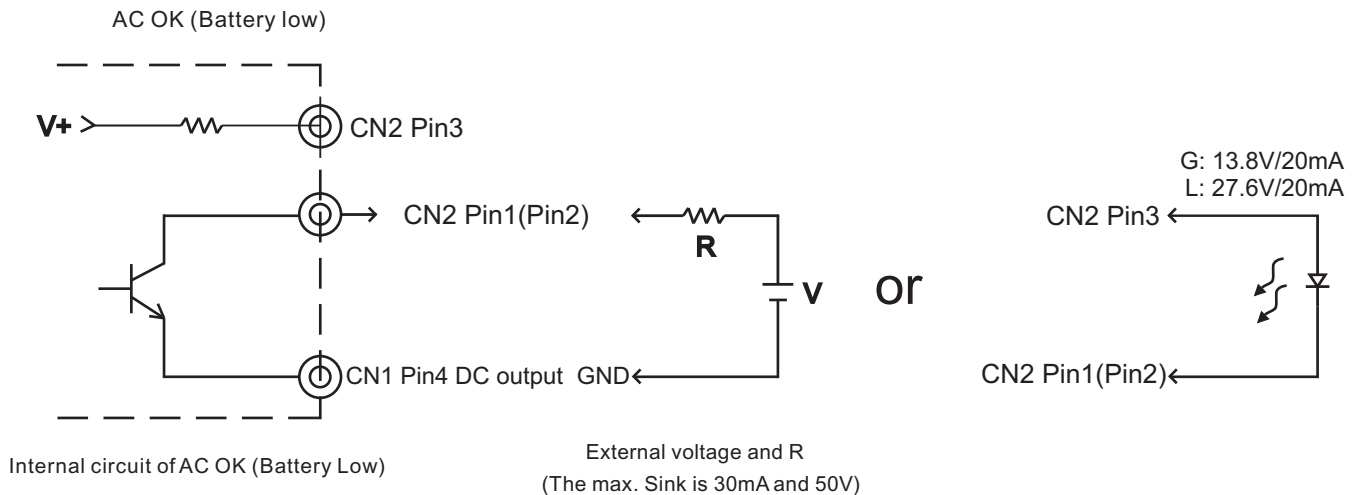

■ For QE-100-GB/LB

■ Block Diagram

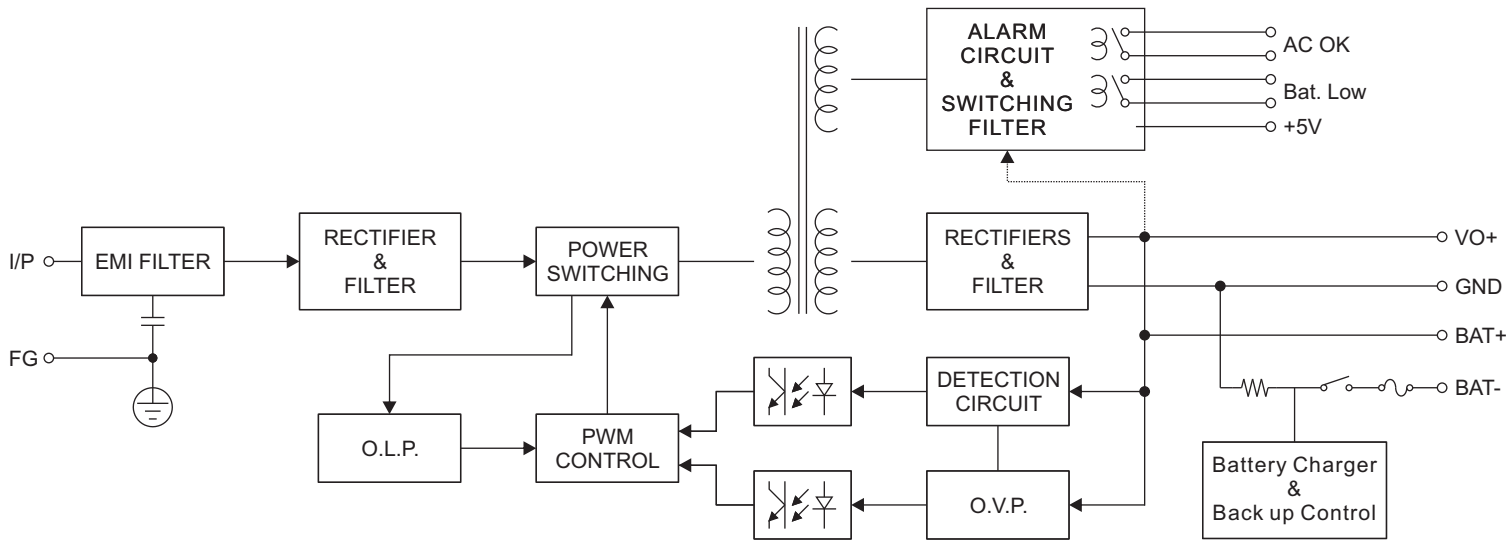

■ Alarm Signal for AC OK and Battery Low

- (1) Alarm Signal is sent out through "AC OK" & "Battery Low" pins. (relay contact type)
- (2) An external voltage source is required for this function. The maximum applied voltage is 30V and the maximum sink current is 1A.
- (3) Table 4.1 explain the alarm function built-in the power supply

Function	Description	Output of alarm
AC OK	The signal is "Low" when the power supply turns on	Low or short
	The signal turns to be "High" when the power supply turns OFF	High or open(External applied voltage 1A max.)
Battery Low	The signal is "Low" when the voltage of battery is under GB:12V , LB:22V	Low or short
	The signal is "High" when the voltage of battery is above GB:12V , LB:22V	High or open(External applied voltage 1A max.)

Table 4.1 Explanation of Alarm Signal

