



# 200-300 WATT MEDICAL SWITCHING POWER SUPPLIES

## DESCRIPTION

The PM300 series comprising single and multiple output models for 200 to 300 watts of continuous output power is specially designed for medical applications not for life support. They operate at 90 to 264VAC input voltage without the need of a selector strap. All auxiliary outputs are with magnetic amplifier to keep regulation. The units are constructed on a printed circuit board with a U-bracket for mechanical support and heat sinking. A cover-and-fan assembly can be added during manufacturing.

## PM300 SERIES



## FEATURES

- EN61000-3-2 class A and D compliant
- Power Factor 0.98 typical
- Overvoltage protection
- Short-circuit protection
- Power Fail Detect (PFD)
- 100% burn-in at full rated load
- Remote sense on output #1 and output #2
- Remote inhibit – TTL high disables output
- Compliant with RoHS requirements

*New!!*

## Safety Standard Approvals :



UL60601-1, CSA C22.2 No. 601.1  
File No. E178020



TÜV EN60601-1  
Certificate No. 50070068

## INPUT SPECIFICATIONS

Input voltage : 90 to 264VAC  
 Input frequency: 47 to 63Hz  
 Input current : 4.7A (rms) for 115VAC  
 2.3A (rms) for 230VAC  
 Earth leakage current: 100uA max. @115VAC, 60Hz  
 220uA max. @ 230VAC, 50Hz

## ENVIRONMENTAL SPECIFICATIONS

Operating temperature : 0°C to +70°C  
 Storage temperature : -40°C to +85°C  
 Relative humidity : 5% to 95% non-condensing  
 Derating : Derate from 100% at +50°C  
 linearly to 50% at +70°C  
 200/250/300 watts continuous  
 output power at 35 CFM forced  
 air cooling or 100/125/150 watts  
 at convention cooling

## OUTPUT SPECIFICATIONS

Output voltage/current : See rating chart  
 Total output power : See rating chart  
 Ripple and Noise : 2% peak to peak maximum  
 Overvoltage protection : Provided on output #1 only;  
 set at 115–140% of its  
 nominal output voltage  
 Overcurrent protection : All outputs protected  
 to short circuit conditions  
 Temperature coefficient : All outputs  $\pm 0.04\%$  /°C  
 maximum  
 Transient response : Maximum excursion of 4%  
 or better on all models,  
 recovering to 1% of final  
 value within 500us after  
 a 25% step load change  
 PFD signal : TTL logic high for normal  
 operation and TTL logic low  
 upon loss of input power.  
 This signal appears at least  
 1ms prior to master output  
 dropping 5% below its  
 nominal value. This signal  
 also provides a minimum  
 delay of 100ms after master  
 output is within regulation.  
 Remote inhibit : Requires an external TTL  
 high level signal to inhibit  
 outputs for standard  
 models.

## GENERAL SPECIFICATIONS

Switching frequency : 70KHz  $\pm 10$ KHz  
 Power factor : 0.98 typical  
 Efficiency : 70% minimum on all models  
 Hold-up time : 12 msec minimum at 110VAC  
 Line regulation :  $\pm 0.2\%$  maximum at full load  
 Inrush current : 30 amps @ 115VAC or 60 amps  
 @230VAC, at 25°C cold start  
 Withstand voltage : 4000VAC from input to output  
 1500VAC from input to ground  
 500VAC from output to ground  
 MTBF : 300,000 hours minimum at full  
 load at 25°C ambient, calculated  
 per MIL-HDBK- 217F  
 EMC Performance (EN60601-1-2: 2001)  
 EN55011: Class B conducted, Class B radiated  
 EN61000-3-2: Harmonic distortion, Class A and D  
 EN61000-3-3: Line flicker  
 EN61000-4-2: ESD,  $\pm 8$ KV air and  $\pm 6$ KV contact  
 EN61000-4-3: Radiated immunity, 3V/m  
 EN61000-4-4: Fast transient/burst,  $\pm 2$ KV  
 EN61000-4-5: Surge,  $\pm 1$ KV diff.,  $\pm 2$ KV com.  
 EN61000-4-6: Conducted immunity, 3Vrms  
 EN61000-4-8: Magnetic field immunity, 3A/m  
 EN61000-4-11: Voltage dips, 30% reduction for 500ms,  
 60% reduction for 100ms and >95%  
 reduction for 10ms

# UNIVERSAL INPUT

# PM300 SERIES

## OUTPUT VOLTAGE/CURRENT RATING CHART

(1) (2) (6) Model	Output # 1 (3)				Output # 2 (3)				Output # 3 (4)				Output # 4 (4)				Maximum Output Power (5)
	Vnom.	Imin.	I <sub>max</sub>	Tol.	Vnom.	Imin.	I <sub>max</sub>	Tol.	Vnom.	Imin.	I <sub>max</sub>	Tol.	Vnom.	Imin.	I <sub>max</sub>	Tol.	
PM300-10-3	3.3V	3.0A	60A	3%													200W
PM300-10	5.1V	3.0A	60A	2%													300W
PM300-12	12V	1.2A	25A	2%													300W
PM300-13	15V	1.0A	20A	2%													300W
PM300-14	24V	0.6A	12.5A	2%													300W
PM300-16	30V	0.5A	10A	2%													300W
PM300-18	48V	0.5A	6.3A	2%													300W
PM300-40-3	3.3V	3.0A	35A	3%	5.1V	2.0A	22A	2%	12V	0A	4A	4%	12V	0A	4A	4%	250W
PM300-40	5.1V	2.0A	35A	2%	12V	1.0A	10A	2%	12V	0A	4A	4%	5.1V	0A	4A	4%	300W
PM300-41	5.1V	2.0A	35A	2%	15V	0.8A	8A	2%	15V	0A	4A	4%	24V	0A	2.5A	4%	300W
PM300-42	5.1V	2.0A	35A	2%	12V	1.0A	10A	2%	12V	0A	4A	4%	12V	0A	4A	4%	300W
PM300-45	5.1V	2.0A	35A	2%	12V	1.0A	10A	2%	12V	0A	4A	4%	24V	0A	2.5A	4%	300W
PM300-46	5.1V	2.0A	35A	2%	12V	1.0A	10A	2%	12V	0A	4A	4%	15V	0A	4A	4%	300W
PM300-47	5.1V	2.0A	35A	2%	24V	0.5A	5A	2%	12V	0A	4A	4%	12V	0A	4A	4%	300W
PM300-48	5.1V	2.0A	35A	2%	24V	0.5A	5A	2%	5.1V	0A	4A	4%	15V	0A	4A	4%	300W
PM300-49	5.1V	2.0A	35A	2%	12V	1.0A	10A	2%	5.1V	0A	4A	4%	24V	0A	2.5A	4%	300W
PM300-410	24V	0.5A	6.3A	2%	12V	1.0A	10A	2%	5.1V	0A	4A	4%	12V	0A	4A	4%	300W
PM300-411	24V	0.5A	6.3A	2%	12V	1.0A	10A	2%	5.1V	0A	4A	4%	24V	0A	2.5A	4%	300W
PM300-412	24V	0.5A	6.3A	2%	12V	1.0A	10A	2%	12V	0A	4A	4%	12V	0A	4A	4%	300W
PM300-413	24V	0.5A	6.3A	2%	24V	0.5A	5A	2%	5.1V	0A	4A	4%	15V	0A	4A	4%	300W
PM300-414	24V	0.5A	6.3A	2%	24V	0.5A	5A	2%	12V	0A	4A	4%	12V	0A	4A	4%	300W

### NOTES:

- Add suffix "B" for U-bracket format or "C" for enclosed format with option fan control, e.g. PM300-45C.
- All outputs are floating. It can be connected externally for positive or negative output.
- Output #1 & #2 can be adjusted within  $\pm 5\%$  of their nominal voltage.
- Output #3 & #4 can be adjusted within  $\pm 15\%$  of their nominal voltage.
- 300 watts for "C" version with cover-and-fan assembly. 150 watts for "B" version without moving air (maximum current of output #1 & #2 derated to 50%), or 300 watts with 35 CFM forced air provided by user.
- PM300-10-3 is rated 200 watts with 35 CFM forced air cooling or 100 watts convection cooled. PM300-40-3 is rated 250 watts with 35 CFM forced air cooling (maximum current of output #1 & #2 derated to 50%) or 125 watts convection cooled.
- Single output models may be operated at no-load. At no-load, output voltage tolerance increases to 10%.

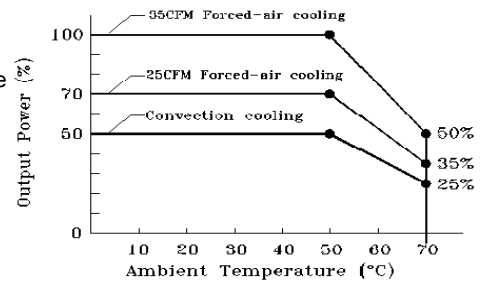

DERATING CURVE

## MECHANICAL SPECIFICATIONS

### Single Output Models

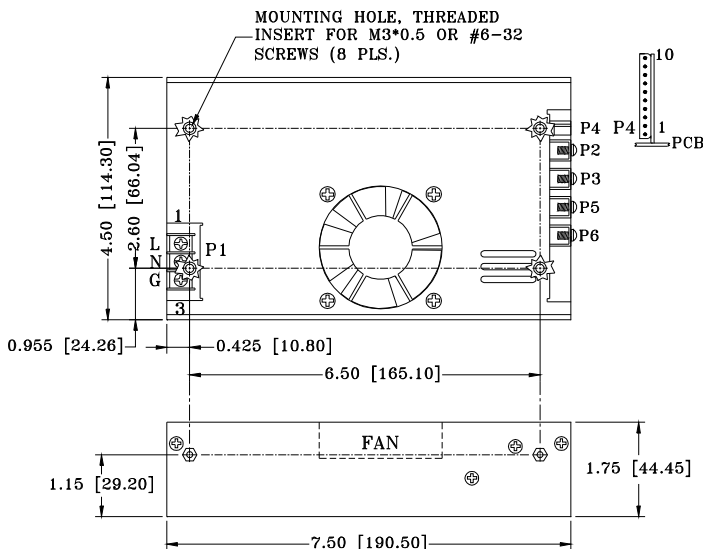

### NOTES:

- Dimensions shown in inch [mm]
- Tolerance 0.02 [0.5] maximum
- Input connector P1 is Dinkle DT-35-B01W-03 screws are M3, Nickel plated.
- Connector P4 mates with Molex housing 50-37-5103 and pins 5263.
- Connectors P2, P3, P5 and P6: M3\*0.5 screw connections
- Weight: 1.20 kgs. (2.64 lbs.) approx.
- DC fan on P4 is rated at 12V/0.1A.

# UNIVERSAL INPUT

## MECHANICAL SPECIFICATIONS

# PM300 SERIES

### Multiple Output Models

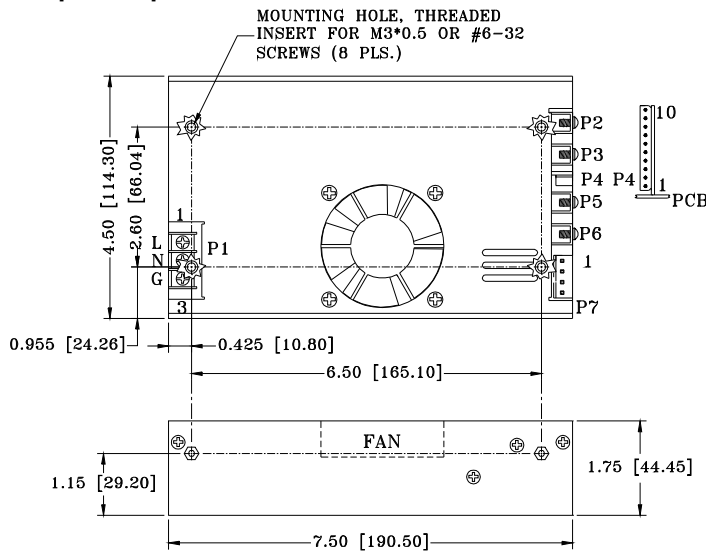

#### NOTES:

1. Dimensions shown in inch [mm]
2. Tolerance 0.02 [0.5] maximum
3. Input connector P1 is Dinkle DT-35-B01W-03 screws are M3, Nickel plated.
4. Connector P4 mates with Molex housing 50-37-5103 and pins 5263.
5. Connectors P2, P3, P5 and P6: M3\*0.5 screw connections
6. Output connector P7 mates with Molex housing 09-50-3041 and Molex 2878 series crimp terminal.
7. Weight: 1.24 kgs. (2.73 lbs.) approx.
8. DC fan on P4 is rated at 12V/0.1A.

### PIN CHART

#### Single Output Models

MODEL	CONN PIN	P1 (AC)			P2	P3	P4			
		1	2	3			1	2	3	4
PM300-10-3 PM300-12 PM300-14 PM300-18	PM300-10 PM300-13 PM300-16	LIVE	NEUTRAL	GROUND	+VO1	+VO1	SIGNAL GROUND (-VO1)	+S (VO1)	-S (VO1)	PFD

MODEL	CONN PIN	P4						P5	P6	P7			
		5	6	7	8	9	10			1	2	3	4
PM300-10-3 PM300-12 PM300-14 PM300-18	PM300-10 PM300-13 PM300-16	INHIBIT	N.C.	N.C.	N.C.	0V (FAN)	FAN	-VO1	-VO1	VOID	VOID	VOID	VOID

#### Multiple Output Models

MODEL	CONN PIN	P1 (AC)			P2	P3	P4			
		1	2	3			1	2	3	4
PM300-40-3 PM300-41 PM300-45 PM300-47 PM300-49 PM300-411 PM300-413	PM300-40 PM300-42 PM300-46 PM300-48 PM300-410 PM300-412 PM300-414	LIVE	NEUTRAL	GROUND	+VO1	-VO1	SIGNAL GROUND (-VO1)	+S (VO1)	-S (VO1)	PFD

MODEL	CONN PIN	P4						P5	P6	P7			
		5	6	7	8	9	10			1	2	3	4
PM300-40-3 PM300-41 PM300-45 PM300-47 PM300-49 PM300-411 PM300-413	PM300-40 PM300-42 PM300-46 PM300-48 PM300-410 PM300-412 PM300-414	INHIBIT	N.C.	+S (VO2)	-S (VO2)	0V (FAN)	FAN	+VO2	-VO2	+VO3	-VO3	+VO4	-VO4