

Features

- World's most compact High Voltage Power Supplies
- Full SMD-Design with Ceramic Capacitors for highest Reliability
- Positive or negative Polarity Models
- PCB- and flying Lead Versions
- Excellent Output stability
- Low Temperature Coefficient
- Ultra low Ripple
- Remote Voltage Programming 0 to 100%
- Short Circuit Protection
- Shielded Metal Case
- 2 Year Product Warranty



The MHV / SHV series are regulated miniature high voltage power modules using SMD and hybrid technology. They are designed for PCB mounting (MHV series) or chassis mounting (SHV series) The use of high stability components guarantees a minimal temperature drift and a very stable output voltage.

Typical applications for these HV power supplies are photomultiplier tubes, gas chromatography, analytical instruments and wherever where small size and high output voltage stability is requested.

Models

Ordercode	Input voltage	Output voltage	Output current max.	Case
MHV 12-180 S 15 P MHV 12-180 S 15 N MHV 12-300 S 10 P MHV 12-300 S 10 N MHV 12-350 S 07 P MHV 12-350 S 07 N MHV 12-0.5 K 6000 P MHV 12-0.5 K 6000 N	12 VDC 10.8 - 13.2 VDC	0... +180 VDC 0... -180 VDC 0... +300 VDC 0... -300 VDC 0... +350 VDC 0... -350 VDC 0... +500 VDC 0... -500 VDC	15 mA 15 mA 10 mA 10 mA 7 mA 7 mA 6 mA 6 mA	A A A A A A B B
MHV 12-1.0 K 2000 P MHV 12-1.0 K 2000 N MHV 12-1.5 K 1300 P MHV 12-1.5 K 1300 N MHV 12-2.0 K 1000 P MHV 12-2.0 K 1000 N	12 VDC 10.8 - 16.5 VDC	0...+1000 VDC 0...-1000 VDC 0...+1500 VDC 0...-1500 VDC 0... +2000 VDC 0...-2000 VDC	2 mA 2 mA 1.3 mA 1.3 mA 1 mA 1 mA	B B B B B B
SHV 12-0.5 K 6000 P SHV 12-0.5 K 6000 N	12 VDC 10.8 - 13.2 VDC	0... +500 VDC 0... -500 VDC	6 mA 6 mA	C C
SHV 12-1.0 K 2000 P SHV 12-1.0 K 2000 N SHV 12-1.5 K 1300 P SHV 12-1.5 K 1300 N SHV 12-2.0 K 1000 P SHV 12-2.0 K 1000 N	12 VDC 10.8 - 16.5 VDC	0...+1000 VDC 0...-1000 VDC 0...+1500 VDC 0...-1500 VDC 0...+2000 VDC 0...-2000 VDC	2 mA 2 mA 1.3 mA 1.3 mA 1 mA 1 mA	C C C C C C

Order code P for positive output polarity
Order code N for negative output polarity



Input Specifications

Input voltage	180, 300, 350 & 500 Vout models other Vout models	+10.8VDC to +13.2 VDC +10.8VDC to +16.5 VDC
Reverse voltage protection		none
Conducted noise (input)		internal filter

Output Specifications

Voltage accuracy		± 5 %
Voltage adjustment range (adjustable with external voltage 0 to +4 VDC or with 5 kOhm variable resistor)		0 – 100%
Remote ON /OFF control (not for 180, 300, 350 Vout models)		ON = pin 2 to pin 5 open OFF = pin 2 to pin 5 short
Regulation	– Input variation Vin min. to Vin max. – Load variation 0 – 100 %	± 0.03 % max. ± 0.08 % max.
Ripple and noise (20 MHz Bandwidth) 500 Vout models	180, 300 & 350 Vout models 1.0, 1.5 & 2.0 kVout models	30 mVpk-pk typ. 10 mVpk-pk typ. 8 mVpk-pk typ.
Temperature coefficient		± 0.01 % / °C
Stability		0.05% 8h after warm-up time
Current limitation		105% of Iout max., fold back
Short circuit protection		indefinite

General Specifications

Temperature ranges	– Operating – Case temperature – Storage	– 10 °C ... + 60 °C + 95 °C max. – 25 °C ... + 85 °C
Derating above 50°C		4% / °C
Humidity (non condensing)		95 % rel H max.
Efficiency		60 – 65%
Reliability, calculated MTBF (MIL-HDBK-217 D)		>300'000 h @ + 25 °C
Isolation voltage	Input/Output	none
Vibration		5 – 100 Hz amplitude 10 mm pk-pk 10 – 55 Hz acceleration 2 G
Shock		acceleration 20 G max. time 11 ms

Physical Specifications

Case material		steel chrom-nickel plated
Weight	MHV models case A MHV models case B SHV models	47 g (1.66 oz) 65 g (2.29 oz) 98 g (3.46 oz)
Soldering temperature		max. 260 °C / 10 sec.

All specifications valid at nominal input voltage, full load and +25°C after warm-up time unless otherwise stated.

Connection Diagram

Connection for remote control by variable resistor

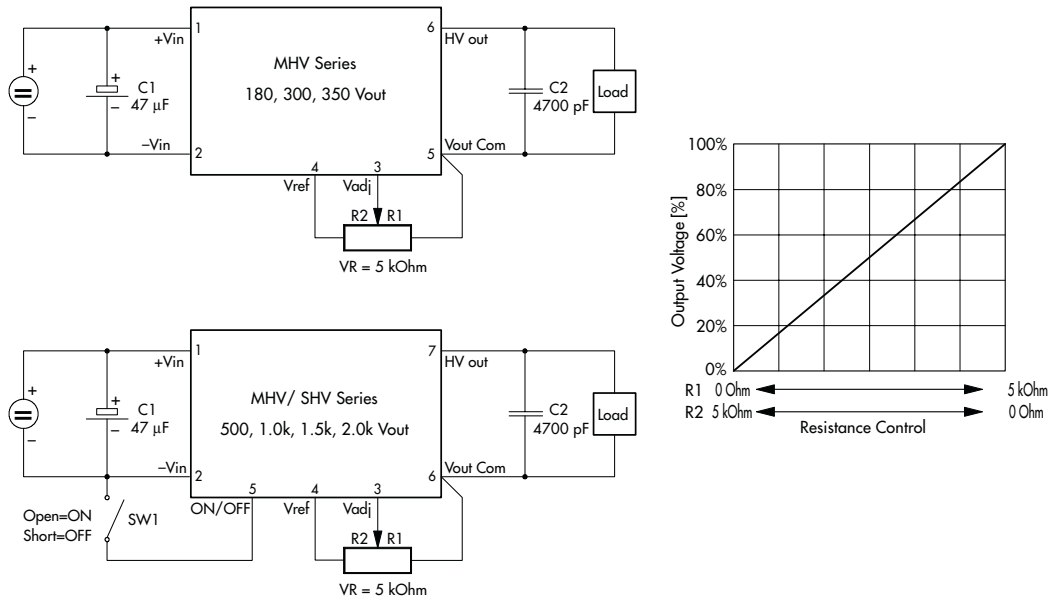

Connection for remote voltage control

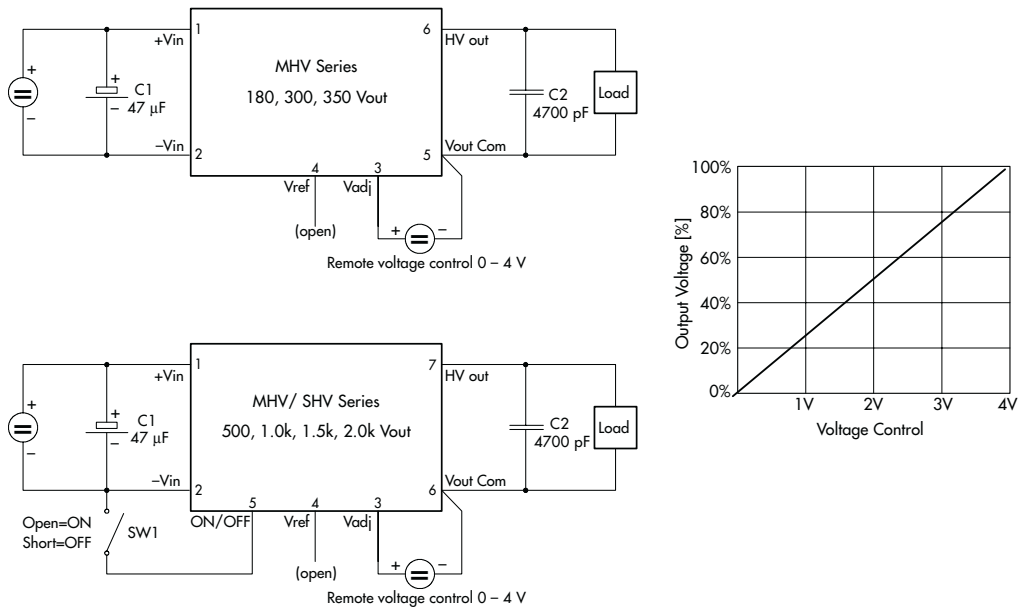

Connection Diagram

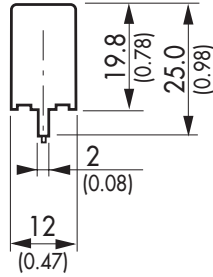
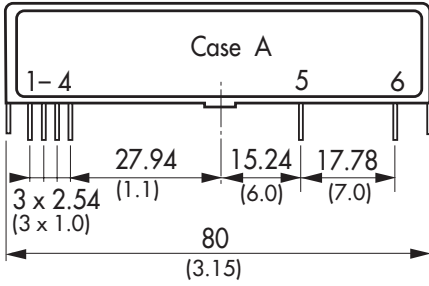

Pin-Out		
Pin	Case A	Case B
1	+Vin (Vcc)	+Vin (Vcc)
2	-Vin (GND)	-Vin (GND)
3	V adj.	V adj.
4	V ref.	V ref.
5	Common	ON / OFF
6	Vout	Common
7	no pin	Vout

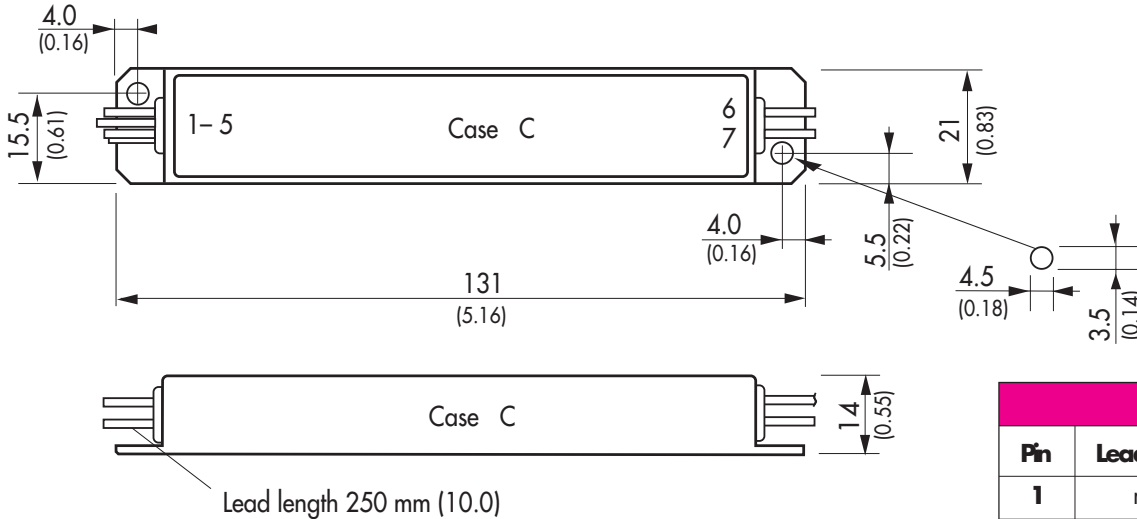
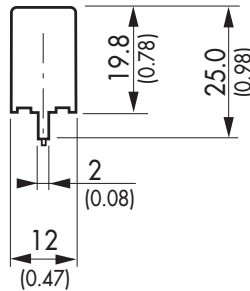
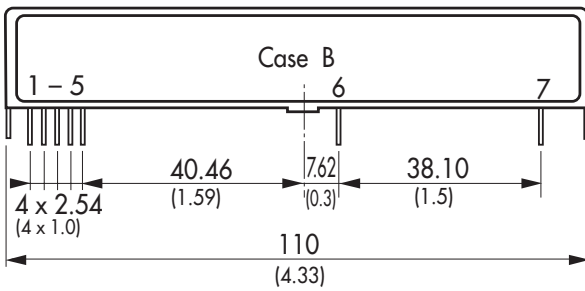

Pin-Out		
Pin	Lead color	Case C
1	red	+Vin (Vcc)
2	black	-Vin (GND)
3	yellow	V adj.
4	orange	V ref.
5	blue	ON / OFF
6	black	Common
7	red	Vout

Pin diameter $\varnothing 0.65 \pm 0.05$ (0.03 \pm 0.002)

Tolerances ± 0.5 (0.02)

Specifications can be changed without notice