

LP DC Power System



Overview:

Eltek Valere's *LP Power System* is an ideal solution for applications requiring up to 7 amps (redundant) at 48V of DC power with load and battery interfaces. Designed to be either wall or rack mounted, the *LP Power System* simplifies installation by integrating power conversion, control, output distribution, and optional battery plant in an innovative 5RU system.

Applications and Benefits

Business communication services

High density power with an optional integrated battery box and DC distribution makes the Eltek Valere *LP DC Power System* the ideal solution for applications powering small multiplexers and FTTx solutions.

Reduced installation and maintenance costs

Integrated, lightweight, and modular chassis make for easy wall or rack mounting. Fully connectorized feeds reduces field wiring time and errors. Hot swappable rectifiers greatly reduce downtime.

Better quality of service

Industry leading efficiency, >1,000,000 hrs MTBF, NEBS Level 3 compliance, redundancy, and intelligently designed distribution all result in reliable, trouble-free networks.

Flexibility of deployment

Battery and power enclosures may be deployed independently. A battery enclosure may be added at any time to provide improved reliability. A power enclosure may be deployed as a stand-alone unit.

Key Features

LP Power Enclosure

- Integrated distribution with 8 GMT fuse positions and system status LED indicators
- Up to two rectifier positions for a redundant power system, with non-redundant configuration option
- Battery thermal compensation
- Four relay alarm contacts for AC supply, rectifier, distribution, and battery alarms

LP Battery Enclosure

- Convenient cables and connectors provided
- Built-in thermal protection with internal temperature sensor and 15A breaker
- Expandable system accommodates daisy chaining of additional battery enclosures (7A-h and 12A-h enclosures only)
- 7 A-h, 12 A-h, and 40 A-h battery enclosures available

LP Power Modules

- C0350A rectifier provides 7A at -48Vdc

LP DC Power System

Technical Specifications

DOCUMENT
2051768 R2

Input Specifications

C SERIES	C0350A	NOTES
Input Voltage (min)	90 Vac	Startup Voltage. Unit operates to 5 V below startup voltage.
Input Voltage (max)	264 Vac	Steady State Voltage. Unit withstands short duration excursions to 264 Vac.
Input Frequency (min)	47 Hz	
Input Frequency (max)	63 Hz	
Input Current (max)		
@ 100 Vac (amps)	4.6	
@ 120 Vac (amps)	3.8	
@ 180 Vac (amps)	2.5	
@ 208 Vac (amps)	2.2	
Inrush Current (max)	30 amps peak	Excludes X caps in the EMC input filter
Power Factor	.98 @ typ.	@ 230Vac, full load

Output Specifications

MAIN OUTPUT	C0350A	NOTES
Vo Set Point (min/typ/max)	42/48/56	Volts
Regulation	±1 (%)	Total regulation line, load, aging and temperature
Output Current (min/max amps)	0/7	
Output Power (watts max)	392	
Current Limit Setpoint (min/max amps)	7.35/8.4	Current limit setpoint is adjustable via I ² C or through Eltek Valere NIC
Short Circuit Current (peak amps)	14	Excluding output capacitor discharge current
Short Circuit Current (RMS amps)	7	
Output Noise*	<ul style="list-style-type: none"> o 20 mV rms typical (10kHz to 20MHz) o 30 dBnc (measured without external battery) o 250mV P-P (10 KHz to 20 MHz) 	
Output Rise Time* (min/max)	100/400 (msec)	Measured at 10 to 90% of final output level
Dynamic Response* (maximum)	3%	Change in output voltage within 10 msecs after a 10 to 100% load step change
Turn On Delay* (max)	3.5 sec	Measured from application of valid AC voltage to regulation set-point
Backup Over-voltage Protection (max)	60 Vdc	
Load Sharing (min/max)	±10 (%) of full load	
Reverse Output Current (max)	0.5 amps	Internal reverse protection is provided
Efficiency	90%	Typical @ 230 Vac

NOTE: *Operating temperature range: -40°C to +65°C

LP DC Power System

Additional Technical Specifications

DOCUMENT
2051768 R2

PHYSICAL SPECIFICATIONS

PARAMETER	C SERIES RECTIFIER	POWER ENCLOSURE	BATTERY ENCLOSURE
Depth	135.2 mm (5.32")	163.5 mm (6.43")	163.5mm (6.43")
Height	74.0 mm (2.91")	86.0 mm (3.4")	130.5mm (5.1")
Width	117.3 mm (4.62")	431.8 mm (17.25")	431.8mm (17.25")
Weight	C0350A: 1.81kg (4lbs)	6.80kg (15lbs) with two rectifiers	14.51kg (32lbs) for 7Ahr system 20.41kg (45lbs) for 12Ahr system

ENVIRONMENTAL SPECIFICATIONS

PARAMETER	MINIMUM	MAXIMUM	UNIT	NOTES
Storage Temperature	-40	85	°C	
Operating Temperature	-40	65	°C	Full power -40°C to +50°C; output power derates 2%/°C above 50°C.
Humidity	5	95	%	Relative Humidity Non Condensing
Altitude	-200	8000	Ft	For operation above 8000' , maximum temperature is derated 2°C per 1000'

GENERAL REQUIREMENTS

APPLICABLE STANDARDS			
NEBS Level 3	GR-63-CORE: Shock and vibration, earthquake zone 4 GR-1089-CORE: EMC, surge standards, electrical safety	EN61000-4-4	Electrical fast transient/burst immunity test
EN55022, Level A	Radiated EMI, conductive emissions	EN61000-4-5	Surge immunity test 1 kV: Line to Line, Criterion A. 2 kV: Line to Ground, Criterion A.
EN61000-3-2	Limits for harmonic current emissions	EN61000-4-6	RF Common Mode. 3Vrms
EN61000-3-3	Limits for voltage fluctuations and flicker in low-voltage systems.	EN61000-4-8	Magnetic Field. 3Vrms
EN61000-4-2	Electrostatic discharge immunity test, 15kV air, 8kV contact	EN61000-4-11	Voltage dips, short interruptions and voltage variations.
EN61000-4-3	Radiated, radio-frequency, electromagnetic field immunity test. Level 3: 10 V/m.		

Specifications are subject to change without notice

LP DC Power System

C-Series Rectifier Diagrams

DOCUMENT
2051768 R2

Top View

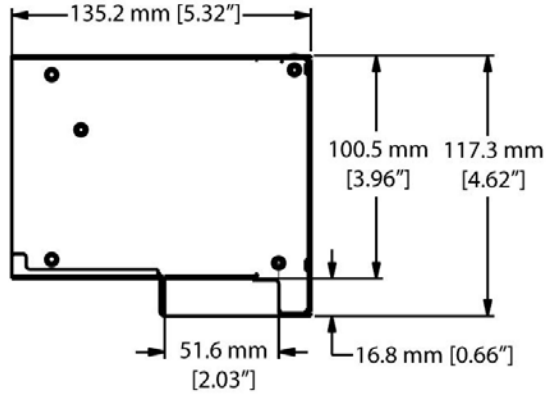

Front View

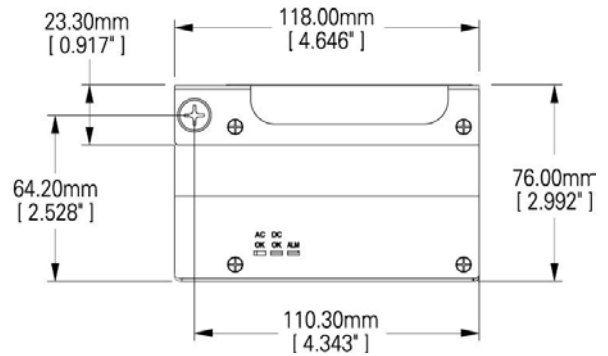

Side View

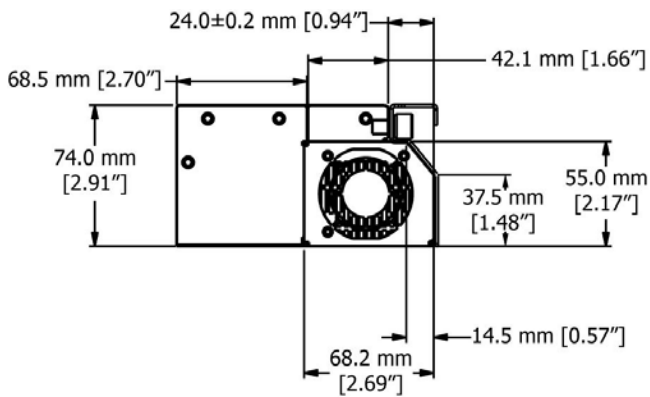

Back View

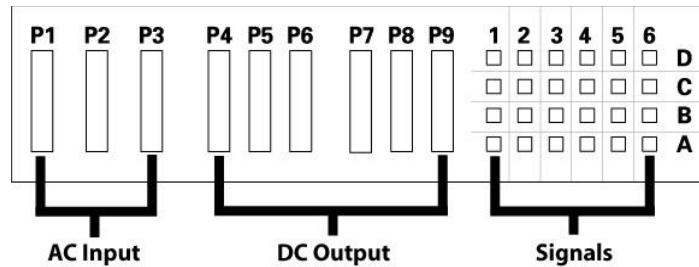
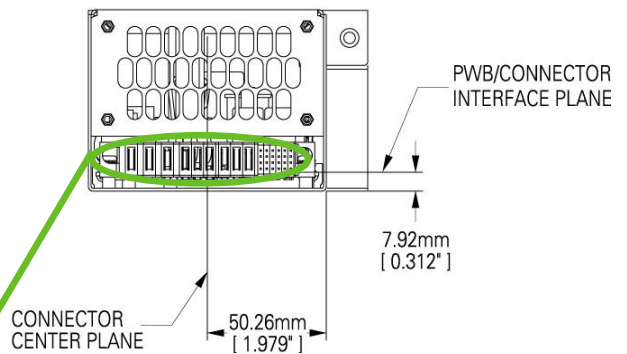

Unit Connector p/n: 51939-140
 Mating Connector p/n: 51940-107
 Supplier: FCI/Berg

FCI NUMBERING	1	2	3	4	5	6
P1	AC LINE 2					
P2	AC LINE 1					
P3	CHASSIS GROUND					
P4	OUTPUT RETURN					
P5						
P6						
P7	OUTPUT POSITIVE					
P8						
P9						
D	OPEN	SHORT_PIN	SDA	LOC2	OPEN	OPEN
C	RTN	OPEN	RESERVED	OPEN	MODULE_PRESENT	OPEN
B	OPEN	RESERVED	LOC0	OPEN	MODULE_PRESENT	MODULE_ALARM
A	ISHARE	SCL	LOC1	OPEN	AC_FAIL	OPEN

LP DC Power System

Rectifier Signals

DOCUMENT
2051768 R2

OUTPUT+ and OUTPUT-

Power blades uses for connecting positive and negative power connections.

SHORT_PIN

The short pin is used to disable the rectifier if not fully seated in a system. It must be connected to OUTPUT- in the system backplane in order for the rectifier to provide proper output voltage. It may not be left un-terminated.

ISHARE

All rectifier ISHARE pins are tied together on the system backplane to support current sharing. This connection may be terminated between rectifiers or left un-terminated in systems where current sharing is not required.

ADDRESS PINS (LOC0, LOC1, LOC2)

LOC0, LOC1, and LOC2 are location pins used to set rectifier address in a system where the I²C bus is shared between rectifiers. If left un-terminated, they generate a logic 1; if connected to OUTPUT-, they generate a logic 0.

I²C COMMUNICATIONS BUS (SCL, SDA)

The I²C communications bus provides information about internal rectifier conditions as well as control of output voltage and alarming set-points. SCL and SDA are common data signals and can be wired directly to a system controller or on a common shared bus between the rectifiers in a system and the main system controller. The rectifiers communicate via the proprietary Eltek Valere Communication Protocol. Contact Eltek Valere for technical assistance in interfacing to the rectifiers using this protocol.

MODULE_PRESENT

This signal is connected internally to LOGIC_GND. It may be used to determine the presence of a rectifier module in a system location.

AC_FAIL

This signal is referenced to RTN within each rectifier. AC_FAIL is a normally closed signal which signifies the presence of an alarm with high impedance. AC_FAIL indicates the presence of valid AC input voltage to the rectifier.

MODULE_ALARM

This signal is referenced to RTN within each rectifier. MODULE_ALARM is a normally closed signal which signifies the presence of an alarm with a high impedance. MODULE_ALARM is designed to provide a power fail warning to indicate the pending loss of DC voltage during line drop conditions. MODULE_ALARM is asserted at least 5msec prior to loss of DC output voltage.

LP DC Power System

LP System Dimension drawings

DOCUMENT
2051768 R2

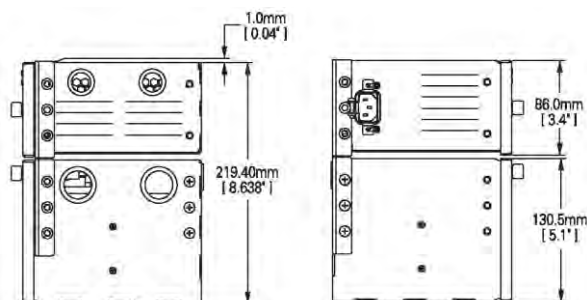
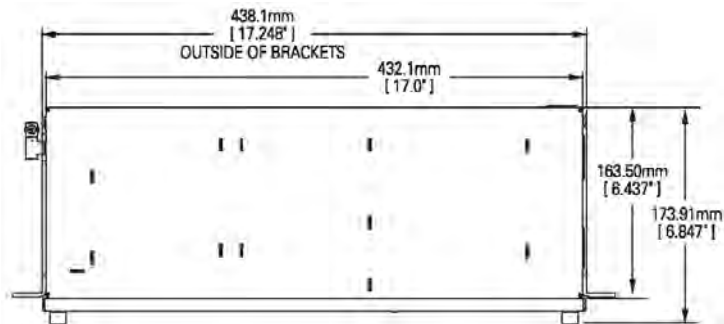
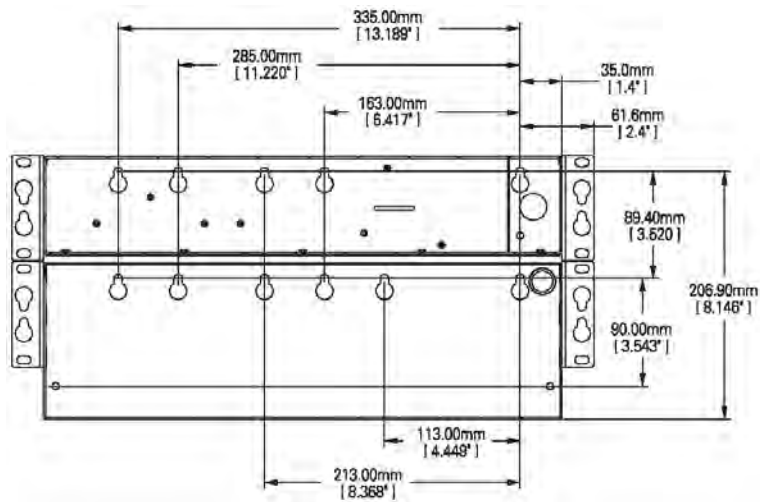
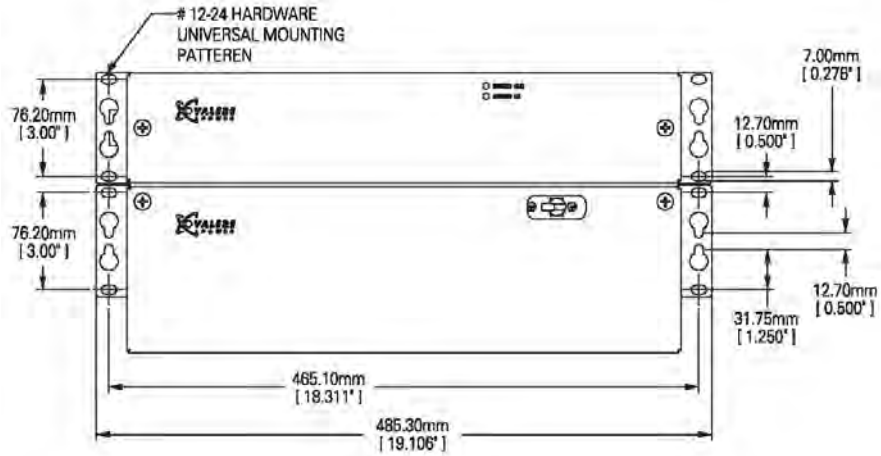

LP DC Power System

Power Enclosure

DOCUMENT
2051768 R2

Enclosure Features

- Wall or rack mountable
- Dual rectifier slots
- Eight GMT fuse positions for loads
- Local Voltage Adjustment
 - Adjustable output voltage
- Battery Thermal Compensation
 - May be enabled or disabled, when enabled reduces system voltage by 72mV/degC above 30°C
- Battery Functionality Test
 - Push button switch reduces rectifier to 45V to force battery discharge, triggering an alarm if batteries cannot support system load
- LED Indicators
 - System OK and System Alarm indication
- Relay Alarms
 - Four contacts, configurable for alarm on open or alarm on close
- Future option for LVD protection

Distribution Card Features

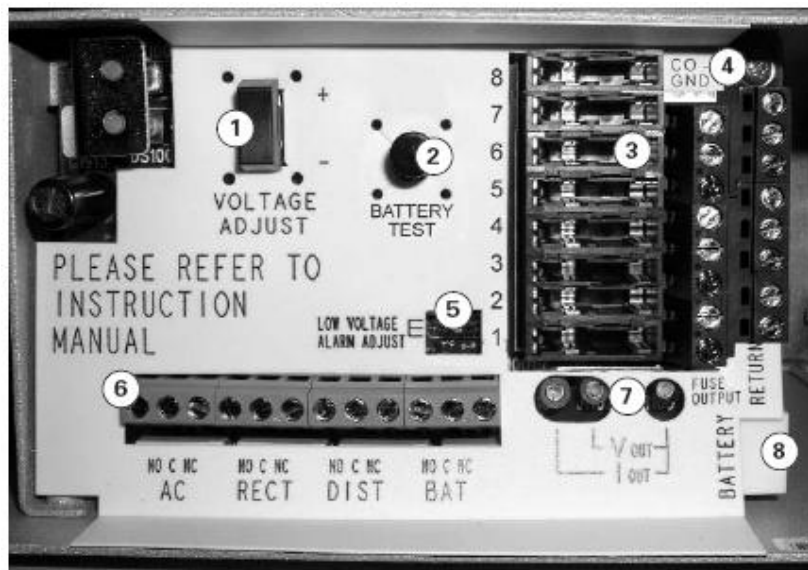

1. "Voltage Adjust" consists of an up/down momentary toggle switch. Default system voltage is set at 54V DC. Pressing the switch will adjust the voltage setup up/down in 50mV increments. Max output voltage is 56V; minimum is 42V.
2. "Battery Test" consists of a momentary push button that can perform two tests. The first is an LED test that checks the functionality of system LEDs. The second is a battery load test, which determines if batteries attached to the system can support system load.
3. Output distribution consists of an eight-position GMT fuse box, with each position rated at 10amps. Output voltage is always negative polarity.
4. "CO GND" is the positive return block for load equipment.
5. "Low Voltage Alarm Adjust" consists of four dipswitches to set the low-voltage threshold as well as activate and deactivate thermal compensation.
6. Form-C alarm relays are provided to detect four system failures: AC FAILURE, RECTIFIER FAILURE, DISTRIBUTION FAILURE, BATTERY FAILURE.
7. Test points are available for measuring output voltage and load current. They are protected from inadvertent short circuit.
8. Battery connector provides power to batteries and monitors battery temperature and breaker.

LP DC Power System

Battery Enclosure Details

DOCUMENT
2051768 R2

Battery Enclosure Features

- Wall or rack mountable
- Supports either 7 or 12Ahr batteries
- Internal thermistor for temperature compensation
- Battery connections individually connectorized for 1/4" fastons
- Battery disconnect breaker removes power from the input feed
- Capable of additional Battery Enclosure daisy chaining

Battery Connector Pin-out

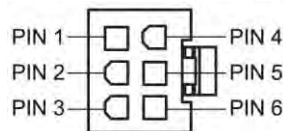
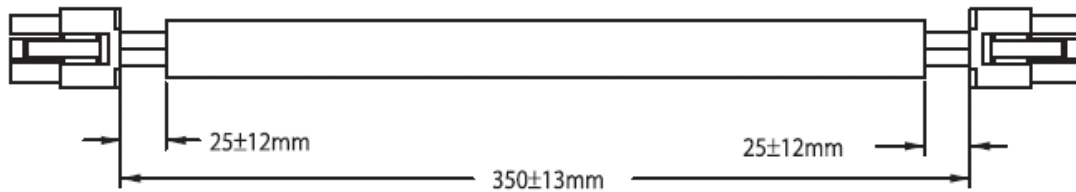

Connector to Power Enclosure Molex Part # 39-01-2065			
Pin 1	V_MAIN+	Pin 4	T_PROBE-
Pin 2	V_MAIN-	Pin 5	BATT_CB_RTN
Pin 3	T_PROBE+	Pin 6	BATT_CB

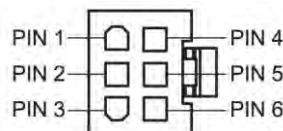

Connector to Battery Enclosure Samtec part # IPBD-03-D			
Pin 1	V_MAIN+	Pin 4	T_PROBE-
Pin 2	V_MAIN-	Pin 5	BATT_CB_RTN
Pin 3	T_PROBE+	Pin 6	BATT_CB